



COMBIVERT F6

INSTRUCTIONS FOR USE | INSTALLATION F6 HOUSING 4

Translation of the original manual
Document 20116235 EN 05





Preface

The described hard- and software are developments of the KEB Automation KG. The enclosed documents correspond to conditions valid at printing. Misprint, mistakes and technical changes reserved.

Signal words and symbols

Certain operations can cause hazards during the installation, operation or thereafter. There are safety informations in the documentation in front of these operations. Security signs are located on the device or machine. A warning contains signal words which are explained in the following table:

 DANGER	Dangerous situation, which will cause death or serious injury in case of non-observance of this safety instruction.
 WARNING	Dangerous situation, which may cause death or serious injury in case of non-observance of this safety instruction.
 CAUTION	Dangerous situation, which may cause minor injury in case of non-observance of this safety instruction.
NOTICE	Situation, which can cause damage to property in case of non-observance.

RESTRICTION

Is used when certain conditions must meet the validity of statements or the result is limited to a certain validity range.



Is used when the result will be better, more economic or trouble-free by following these procedures.

More symbols

- ▶ This arrow starts an action step.
- / - Enumerations are marked with dots or indents.
- => Cross reference to another chapter or another page.



Note to further documentation.
www.keb.de/service/downloads



Laws and guidelines

KEB Automation KG confirms with the EC declaration of conformity and the CE mark on the device nameplate that it complies with the essential safety requirements.

The EC declaration of conformity can be downloaded on demand via our website. Further information is provided in chapter "Certification".

Warranty and liability

The warranty and liability on design, material or workmanship for the acquired device is given in the general sales conditions.



Here you will find our general sales conditions.
www.keb.de/terms-and-conditions



Further agreements or specifications require a written confirmation.

Support

Through multiple applications not every imaginable case has been taken into account. If you require further information or if problems occur which are not treated detailed in the documentation, you can request the necessary information via the local KEB Automation KG agency.

The use of our units in the target products is outside of our control and therefore lies exclusively in the area of responsibility of the customer.

The information contained in the technical documentation, as well as any user-specific advice in spoken and written and through tests, are made to best of our knowledge and information about the intended use. However, they are regarded as being only informal and changes are expressly reserved, in particular due to technical changes. This also applies to any violation of industrial property rights of a third-party. Selection of our units in view of their suitability for the intended use must be done generally by the user.

Tests can only be done within the intended end use of the product (application) by the customer. They must be repeated, even if only parts of hardware, software or the unit adjustment are modified.

Copyright

The customer may use the instructions for use as well as further documents or parts from it for internal purposes. Copyrights are with KEB Automation KG and remain valid in its entirety.

This KEB product or parts thereof may contain third-party software, including free and/or open source software. If applicable, the license terms of this software are contained in the instructions for use. The instructions for use are already available to you, can be downloaded free of charge from the KEB website or can be requested from the respective KEB contact person.

Other wordmarks or/and logos are trademarks (™) or registered trademarks (®) of their respective owners.

Table of Contents

Preface	3
Signal words and symbols	3
More symbols.....	3
Laws and guidelines.....	4
Warranty and liability.....	4
Support	4
Copyright.....	4
Table of Contents	5
List of Figures	9
List of Tables	10
Glossary	12
Standards for drive converters/control cabinets	14
Product standards that apply directly to the drive converter	14
Basic standards to which drive converter standards refer directly	14
Standards that are used in the environment of the drive converter	15
1 Basic Safety Instructions	16
1.1 Target group.....	16
1.2 Transport, storage and proper use	16
1.3 Installation.....	17
1.4 Electrical connection	18
1.4.1 EMC-compatible installation.....	19
1.4.2 Voltage test.....	19
1.4.3 Insulation measurement.....	19
1.5 Start-up and operation	20
1.6 Maintenance.....	21
1.8 Repair	22
1.7 Disposal.....	22
2 Product Description	23
2.1 Specified application.....	23
2.1.1 Residual risks	23
2.2 Unintended use.....	23
2.3 Product features	24
2.4 Part code	25
2.5 Nameplate	27
2.5.1 Configurable options	28
3 Technical Data	29
3.1 Operating conditions	29
3.1.1 Climatic environmental conditions.....	29
3.1.2 Mechanical environmental conditions	30

TABLE OF CONTENTS

3.1.3 Chemical / mechanical active substances.....	30
3.1.4 Electrical operating conditions.....	31
3.1.4.1 Device classification.....	31
3.1.4.2 Electromagnetic compatibility.....	31
3.2 Device data of the 230V devices	32
3.2.1 Overview of the 230V devices.....	32
3.2.2 Voltage and frequencies for 230V devices.....	33
3.2.2.1 Example of the calculation of the possible motor voltage 230V:.....	34
3.2.3.1 Overload characteristic (OL) for 230V devices.....	35
3.2.3.2 Frequency-dependent maximum current (OL2) for 230V devices.....	36
3.2.3 Input and output currents / overload for 230V devices.....	34
3.2.4 Power dissipation at rated operation for 230V devices.....	38
3.2.5 Fuse protection of the drive converters for 230V devices.....	39
3.3 Device data of the 400V devices	40
3.3.1 Overview of the 400V devices.....	40
3.3.2 Voltage and frequencies for 400V devices.....	41
3.3.3 Input and output currents / overload for 400V devices.....	42
3.3.2.1 Example of the calculation of the possible motor voltage:.....	42
3.3.3.1 Overload characteristic (OL) for 400 V devices.....	43
3.3.3.2 Frequency-dependent maximum current (OL2) 400V devices.....	44
3.3.4 Power dissipation at nominal operating for 400 V devices.....	49
3.3.5 Fuse protection of the drive converters 400 V devices.....	49
3.4 General electrical data	50
3.4.1 Switching frequency and temperature.....	50
3.4.2 DC link / braking transistor function (GTR7).....	51
3.4.2.1 DC link / braking transistor function of the 230V devices.....	52
3.4.2.2 DC link / braking transistor function of the 400V devices.....	53
3.4.3 Fan.....	53
3.4.3.1 Switching behaviour of the fans.....	54
3.4.3.2 Switching points of the fans.....	54
3.4.3.3 Airflow of the drive converter.....	55
3.5 Dimensions and weights	56
3.5.1 Built-in version air cooler.....	56
3.5.2 Built-in version fluid cooler (water).....	57
3.5.3 Push-through version air cooler IP20, IP54-ready.....	58
3.5.4 Push-through version fluid cooler (water) IP20, IP54-ready.....	59
3.5.5 Push-through version fluid cooler (oil) IP54-ready.....	60
3.5.6 Control cabinet installation.....	61
3.5.6.1 Mounting instructions.....	61
3.5.6.2 Mounting distances.....	62

4	Installation and Connection.....	63
4.1	Overview of the COMBIVERT F6.....	63
4.2	Connection of the power unit.....	66
4.2.1	Connection of the voltage supply	66
4.2.1.1	Terminal block X1A.....	67
4.2.2	Protective earth and functional earth.....	68
4.2.2.1	Protective earth	68
4.2.2.2	Functional earthing.....	68
4.2.3	AC mains connection.....	69
4.2.3.1	AC supply 3-phase	69
4.2.3.2	Mains supply line.....	69
4.2.3.3	Note on hard power systems.....	70
4.2.4	DC connection.....	71
4.2.4.1	Terminal block X1A DC connection	71
4.2.5	Connection of the motor.....	72
4.2.5.1	Wiring of the motor	72
4.2.5.2	Terminal block X1A motor connection	72
4.2.5.3	Motor cable length and conducted interferences at AC supply	73
4.2.5.4	Selection of the motor line.....	73
4.2.5.5	Motor cable length for parallel operation of motors	74
4.2.5.6	Motor cable cross-section	74
4.2.5.7	Interconnection of the motor.....	74
4.2.5.8	Connection of the temperature monitoring and brake control (X1C).....	75
4.2.6	Connection and use of a braking resistor.....	77
4.2.6.1	Installation instructions for side-mounted braking resistors.....	77
4.2.6.2	Terminal block X1A connection braking resistor.....	78
4.2.6.3	Wiring of an intrinsically safe braking resistor	79
4.2.6.4	Using a non-intrinsically safe braking resistor	79
4.3	Accessories	80
4.3.1	Filters and chokes	80
4.3.2	Shield connection bracket mounting kit.....	80
4.3.3	Side-mounted braking resistors.....	80
5	Installation and Operation of Liquid-Cooled Devices	81
5.1	Water-cooled devices.....	81
5.1.1	Heat sink and operating pressure	81
5.1.2	Materials in the cooling circuit	81
5.1.3	Requirements for the coolant	82
5.1.4	Connection of the water cooling system.....	84
5.1.5	Coolant temperature and moisture condensation	85
5.1.5.1	Moisture condensation	86
5.1.5.2	Supply of temper coolant.....	86

TABLE OF CONTENTS

5.1.6 Permissible flow rate with water cooling.....	87
5.1.7 Coolant heating	88
5.1.8 Typical pressure drop of the heat sink.....	88
5.2 Oil-cooled devices.....	89
5.2.1 Heat sink and operating pressure for oil-cooled devices.....	89
5.2.2 Oil requirements.....	89
5.2.3 Connection of the oil cooling system.....	90
5.2.4 Permissible flow rate for oil	90
5.2.5 Coolant temperature and moisture condensation	91
5.2.5.1 Avoid moisture condensation	91
6 Certification.....	92
6.1 CE-Marking.....	92
6.2 UL certification	93
6.3 Further informations and documentation.....	94
7 Revision History	95

List of Figures

Figure 1:	Nameplate.....	27
Figure 2:	Configurable options	28
Figure 3:	Switch-off time t depending on the overload I/IN at OC level 180 % (OL).....	35
Figure 4:	Typical overload characteristics in the lower output frequencies (OL2) Example. Device size 18.....	37
Figure 5:	Switch-off time t depending on the overload I/IN at OC level 180 % (OL).....	43
Figure 6:	Typical overload characteristics in the lower output frequencies (OL2) Example. Device size 19.....	45
Figure 7:	Block diagram of the energy flow.....	51
Figure 8:	Switching behaviour of the fans example heat sink fan	54
Figure 9:	Airflow of the drive converter	55
Figure 10:	Dimensions built-in version air cooler	56
Figure 11:	Dimensions built-in version fluid cooler (water)	57
Figure 12:	Dimensions push-through version air cooler IP20, IP54-ready	58
Figure 13:	Dimensions push-through version fluid cooler (water) IP20, IP54-ready.....	59
Figure 14:	Dimensions push-through version fluid cooler (oil) IP54-ready	60
Figure 15:	Mounting distances	62
Figure 16:	Control cabinet ventilation.....	62
Figure 17:	F6 housing 4 top view	63
Figure 18:	F6 housing 4 front view.....	64
Figure 19:	F6 housing 4 rear view with control board COMPACT	65
Figure 20:	Input circuit.....	66
Figure 21:	Terminal block X1A	67
Figure 22:	Connection for protective earth.....	68
Figure 23:	Connection of the mains supply 3-phase.....	69
Figure 24:	Terminal block X1A DC connection.....	71
Figure 25:	Wiring of the motor.....	72
Figure 26:	Terminal block X1A DC connection.....	72
Figure 27:	Symmetrical motor line	73
Figure 28:	Terminal block X1C for control board APPLICATION and COMPACT.....	75
Figure 29:	Terminal block X1C for control board PRO	75
Figure 30:	Connection of the brake control.....	76
Figure 31:	Connection of a KTY sensor	76
Figure 32:	Terminal block X1A DC connection.....	78
Figure 33:	Wiring of an intrinsically safe braking resistor.....	79
Figure 34:	Open pipe ends for the connection of the water cooling system	84
Figure 35:	Volume flow depending on the total power dissipation and temperature difference with water.....	88
Figure 36:	Typical pressure drop depending on the flow rate	88
Figure 37:	Connection of the oil cooling system	90

List of Tables

Table 1:	Part code.....	25
Table 2:	Climatic environmental conditions	29
Table 3:	Mechanical environmental conditions	30
Table 4:	Chemical / mechanical active substances	30
Table 5:	Device classification.....	31
Table 6:	Electromagnetic compatibility	31
Table 7:	Overview of the 230V device data	33
Table 8:	Input voltages and frequencies of the 230V devices	33
Table 9:	DC link voltage for 230V devices	33
Table 12:	Input currents of the 230V devices	34
Table 13:	Output currents 230V devices.....	34
Table 10:	Output voltages and frequencies of the 230V devices	34
Table 11:	Example of the calculation of the possible motor voltage 230V:.....	34
Table 14:	Frequency-dependent maximum current for device size 18	38
Table 15:	Power dissipation of the 230V devices	38
Table 16:	Fusing of the 230 V / 240 V devices.....	39
Table 17:	Overview of the 400 V device data	41
Table 18:	Input voltages and frequencies of the 400V devices	41
Table 19:	DC link voltage for 400V devices	41
Table 22:	Input currents of the 400 V devices	42
Table 23:	Output currents 400 V devices.....	42
Table 20:	Output voltages and frequencies of the 400V devices	42
Table 21:	Example of the calculation of the possible motor voltage:	42
Table 24:	Frequency-dependent maximum current for device size 18	46
Table 25:	Frequency-dependent maximum current for device size 19	46
Table 26:	Frequency-dependent maximum current for device size 20	47
Table 27:	Frequency-dependent maximum current for device size 21	47
Table 28:	Frequency-dependent maximum current for device size 22	48
Table 29:	Power dissipation of the 400 V devices	49
Table 30:	Fusing of the 400 V / 480 V devices	49
Table 31:	Switching frequency and temperature	50
Table 32:	DC link / braking transistor function of the 230V devices.....	52
Table 33:	DC link / braking transistor function of the 400V devices.....	53
Table 34:	Fan.....	53
Table 35:	Switching points of the fans	54
Table 36:	Mounting instructions for built-in version.....	61
Table 37:	Mounting instructions for push-through version	61
Table 38:	Max. motor cable length.....	73
Table 39:	Filters and chokes for 230V devices	80
Table 40:	Filters and chokes 400V devices	80
Table 41:	Shield connection bracket mounting kit	80
Table 42:	Electrochemical series / standard potentials against hydrogen	82
Table 43:	Requirements for the coolant.....	82

Table 44:	Special requirements for open and half-open cooling systems	83
Table 45:	Dew point table	86
Table 46:	Permissible flow rate with water cooling	87
Table 47:	Oil requirements.....	89
Table 48:	Special requirements for open and semi-open cooling systems for oil coolers	89
Table 49:	Permissible flow rate for the oil cooler	90
Table 50:	Dew point table	91

Glossary

0V	Earth-potential-free common point	Endat	Bidirectional encoder interface of the company Heidenhain
1ph	1-phase mains	EtherCAT	Real-time Ethernet bus system of the company Beckhoff
3ph	3-phase mains	Ethernet	Real-time bus system - defines protocols, plugs, types of cables
AC	AC current or voltage	FE	Functional earth
AFE	From 07/2019 AIC replaces the previous name AFE	FSoE	Functional Safety over Ethernet
AFE filter	From 07/2019 AIC filter replaces the previous name AFE filter	FU	Drive converter
AIC	Active Infeed Converter	GND	Reference potential, ground
AIC filter	Filter for Active Infeed Converter	GTR7	Braking transistor
Application	The application is the intended use of the KEB product	HF filter	High frequency filter to the mains
ASCL	Asynchronous sensorless closed loop	Hiperface	Bidirectional encoder interface of the company Sick-Stegmann
Auto motor ident.	Automatically motor identification; calibration of resistance and inductance	HMI	Human machine interface (touch screen)
AWG	American wire gauge	HSP5	Fast, serial protocol
B2B	Business-to-business	HTL	Incremental signal with an output voltage (up to 30V) -> TTL
BiSS	Open source real-time interface for sensors and actuators (DIN 5008)	IEC	International standard
CAN	Fieldbus system	IP xx	Degree of protection (xx for level)
CDF	Cyclic duration factor	KEB product	The KEB product is subject of this manual
CDM	Complete drive module including auxiliary equipment (control cabinet)	KTY	Silicium temperature sensor (polarized)
COMBIVERT	KEB drive converters	Manufacturer	The manufacturer is KEB, unless otherwise specified (e.g. as manufacturer of machines, engines, vehicles or adhesives)
COMBIVIS	KEB start-up and parameterizing software	MCM	American unit for large wire cross sections
Customer	The customer has purchased a KEB product from KEB and integrates the KEB product into his product (customer product) or resells the KEB product (dealer)	Modulation	Means in drive technology that the power semiconductors are controlled
DC	DC current or voltage	MTTF	Mean service life to failure
DI	Demineralized water, also referred to as deionized (DI) water	NN	Sea level
DIN	German Institut for standardization	OC	Overcurrent
DS 402	CiA DS 402 - CAN device profile for drives	OH	Overheat
EMC	Electromagnetic compatibility	OL	Overload
Emergency stop	Shutdown of a drive in emergency case (not de-energized)	OSSD	Output signal swithching device; - an output signal that is checked in regular intervals on its shutdown. (safety technology)
Emergency switching off	Switching off the voltage supply in emergency case	PDS	Power drive system incl. motor and measuring probe
EMS	Energy Management System	PE	Protective earth
EN	European standard	PELV	Protective Extra Low Voltage
Encoder emulation	Software-generated encoder output	PFD	Term used in the safety technology (EN 61508-1...7) for the size of error probability
End customer	The end customer is the user of the customer product		

PFH	Term used in the safety technology (EN 61508-1...7) for the size of error probability per hour
PLC	Programmable logic controller
PT100	Temperature sensor with $R_0=100\Omega$
PT1000	Temperature sensor with $R_0=1000\Omega$
PTC	PTC-resistor for temperature detection
PWM	Pulse width modulation
RJ45	Modular connector with 8 lines
SCL	Synchronous sensorless closed loop
SELV	Safety Extra Low Voltage (< 60 V)
SIL	The security integrity level is a measure for quantifying the risk reduction. Term used in the safety technology (EN 61508 -1...7)
SS1	Safety function „Safe stop 1“ in accordance with IEC 61800-5-2
SSI	Synchronous serial interface for encoder
STO	Safety function „Safe Torque Off“ in accordance with IEC 61800-5-2
TTL	Incremental signal with an output voltage up to 5V
USB	Universal serial bus
VARAN	Real-time Ethernet bus system

Standards for drive converters / control cabinets

Product standards that apply directly to the drive converter

EN61800-2	Adjustable speed electrical power drive systems - Part 2: General requirements - Rating specifications for low voltage adjustable frequency a.c. power drive systems (VDE 0160-102, IEC 61800-2)
EN61800-3	Speed-adjustable electrical drives. Part 3: EMC requirements and specific test methods (VDE 0160-103, IEC 61800-3)
EN61800-5-1	Adjustable speed electrical power drive systems - Part 5-1: Safety requirements - Electrical, thermal and energy (IEC 61800-5-1); German version EN 61800-5-1
EN61800-5-2	Adjustable speed electrical power drive systems - Part 5-2: Safety Requirements - Functional (IEC 22G/264/CD)
UL61800-5-1	American version of the EN61800-5-1 with „National Deviations“

Basic standards to which drive converter standards refer directly

EN 55011	Industrial, scientific and medical equipment - Radio frequency disturbance characteristics - Limits and methods of measurement (CISPR 11); German version EN 55011
EN 55021	Interference to mobile radiocommunications in the presence of impulse noise - Methods of judging degradation and measures to improve performance (IEC/ CISPR/D/230/FDIS); German version prEN 55021
EN 60529	Degrees of protection provided by enclosures (IP Code) (IEC 60529)
EN 60664-1	Insulation coordination for equipment within low-voltage systems Part 1: Principles, requirements and tests (IEC 60664-1)
EN 60721-3-1	Classification of environmental conditions - Part 3-1: Classification of groups of environmental parameters and their severities - Section 1: Storage (IEC 60721-3-1); German version EN 60721-3-1
EN 60721-3-2	Classification of environmental conditions - Part 3: Classification of groups of environmental parameters and their severities - Section 2: Transportation and handling (IEC 104/670/CD)
EN 60721-3-3	Classification of environmental conditions - Part 3: Classification of groups of environmental parameters and their severities; section 3: Stationary use at weatherprotected locations; Amendment A2 (IEC 60721-3-3); German version EN 60721-3-3
EN 61000-2-1	Electromagnetic compatibility (EMC) - Part 2: Environment - Section 1: Description of the environment - Electromagnetic environment for low-frequency conducted disturbances and signalling in public power supply systems
EN 61000-2-4	Electromagnetic compatibility (EMC) - Part 2-4: Environment; Compatibility levels in industrial plants for low-frequency conducted disturbances (IEC 61000-2-4); German version EN 61000-2-4
EN 61000-4-2	Electromagnetic compatibility (EMC) - Part 4-2: Testing and measurement techniques - Electrostatic discharge immunity test (IEC 61000-4-2); German version EN 61000-4-2
EN 61000-4-3	Electromagnetic compatibility (EMC) - Part 4-3: Testing and measurement techniques - Radiated, radio-frequency, electromagnetic field immunity test (IEC 61000-4-3); German version EN 61000-4-3
EN 61000-4-4	Electromagnetic compatibility (EMC) - Part 4-4: Testing and measurement techniques - Electrical fast transient/burst immunity test (IEC 61000-4-4); German version EN 61000-4-4

EN61000-4-5	Electromagnetic compatibility (EMC) - Part 4-5: Testing and measurement techniques - Surge immunity test (IEC 61000-4-5); German version EN 61000-4-5
EN61000-4-6	Electromagnetic compatibility (EMC) - Part 4-6: Testing and measurement techniques - Immunity to conducted disturbances, induced by radio-frequency fields (IEC 61000-4-6); German version EN 61000-4-6
EN61000-4-34	Electromagnetic compatibility (EMC) - Part 4-34: Testing and measurement techniques - Voltage dips, short interruptions and voltage variations immunity tests for equipment with mains current more than 16 A per phase (IEC 61000-4-34); German version EN 61000-4-34
EN61508-1...7	Functional safety of electrical/electronic/programmable electronic safety-related systems – Part 1...7 (VDE 0803-1...7, IEC 61508-1...7)
EN62061	Safety of machinery - functional safety of electrical, electronic and programmable electronic safety-related systems (VDE 0113-50, IEC 62061)
EN ISO 13849-1	Safety of machinery - safety-related parts of control systems - Part 1: General principles for design (ISO 13849-1); German version EN ISO 13849-1

Standards that are used in the environment of the drive converter

DGUV regulation 3	Electrical installations and equipment
DIN 46228-1	Wire-end ferrules; Tube without plastic sleeve
DIN 46228-4	Wire-end ferrules; Tube with plastic sleeve
DIN IEC 60364-5-54	Low-voltage electrical installations - Part 5-54: Selection and erection of electrical equipment - Earthing arrangements, protective conductors and protective bonding conductors (IEC 64/1610/CD)
DIN VDE 0100-729	Low-voltage electrical installations - Part 7-729: Requirements for special installations or locations - Operating or maintenance gangways (IEC 60364-7-729:2007, modified); German implementation HD 60364-7-729:2009
DNVGL-CG-0339	Environmental test specification for electrical, electronic and programmable equipment and systems
EN 1037	Safety of machinery - Prevention of unexpected start-up; German version EN 1037
EN 12502-1...5	Protection of metallic materials against corrosion - Part 1...5
EN 60204-1	Safety of machinery - electrical equipment of machines Part 1: General requirements (VDE 0113-1, IEC 44/709/CDV)
EN 60439-1	Low-voltage switchgear and controlgear assemblies - Part 1: Type-tested and partially type-tested assemblies (IEC 60439-1); German version EN 60439-1
EN 60947-7-1	Low-voltage switchgear and controlgear - Part 7-1: Ancillary equipment - Terminal blocks for copper conductors (IEC 60947-7-1:2009); German version EN 60947-7-1:2009
EN 60947-8	Low-voltage switchgear and controlgear - Part 8: Control units for built-in thermal protection (PTC) for rotating electrical machines (IEC 60947-8:2003 + A1:2006 + A2:2011)
EN 61373	Railway applications - Rolling stock equipment - Shock and vibration tests (IEC 61373); German version EN 61373
EN 61439-1	Low-voltage switchgear and controlgear assemblies - Part 1: General rules (IEC 121B/40/CDV); German version FprEN 61439-1
VGB R 455 P	Water treatment and use of materials in cooling systems
ISO 4017	Fasteners - Hexagon head screws - Product grades A and B
ISO 4762	Hexagon socket head cap screws
ISO 7090	Plain washers, chamfered - Normal series - Product grade A
ISO 7092	Plain washers - Small series - Product grade A
ISO 7045	Pan head screws with type H or type Z cross recess - Product grade A

1 Basic Safety Instructions

The COMBIVERT is designed and constructed in accordance with state-of-the-art technology and the recognised safety rules and regulations. However, the use of such devices may cause functional hazards for life and limb of the user or third parties, or damages to the system and other material property.

The following safety instructions have been created by the manufacturer for the area of electric drive technology. They can be supplemented by local, country- or application-specific safety instructions. This list is not exhaustive. Non-observance of the safety instructions by the customer, user or other third party leads to the loss of all resulting claims against the manufacturer.

NOTICE



Hazards and risks through ignorance.

- ▶ Read the instructions for use !
- ▶ Observe the safety and warning instructions !
- ▶ If anything is unclear, please contact KEB Automation KG !

1.1 Target group

This instruction manual is determined exclusively for electrical personnel. Electrical personnel for the purpose of this instruction manual must have the following qualifications:

- Knowledge and understanding of the safety instructions.
- Skills for installation and assembly.
- Start-up and operation of the product.
- Understanding of the function in the used machine.
- Detection of hazards and risks of the electrical drive technology.
- Knowledge of [DIN IEC 60364-5-54](#).
- Knowledge of national safety regulations.

1.2 Transport, storage and proper use

The transport is carried out by qualified persons in accordance with the environmental conditions specified in this manual. Drive converter shall be protected against excessive strains.



Transport of drive converters with an edge length >75 cm

The transport by forklift without suitable tools can cause a deflection of the heat sink. This leads to premature aging or destruction of internal components.

- ▶ Transport of drive converters on suitable pallets.
- ▶ Do not stack drive converters or burden them with other heavy objects.



Drive converters contain electrostatic sensitive components.

- ▶ Avoid contact.
 - ▶ Wear ESD-protective clothing.
-

Do not store drive converters

- in the environment of aggressive and/or conductive liquids or gases.
- with direct sunlight.
- outside the specified environmental conditions.

1.3 Installation

⚠ DANGER

Do not operate in an explosive environment!

- ▶ The COMBIVERT is not intended for the use in potentially explosive environment.
-

⚠ CAUTION

Maximum design edges and high weight!
Contusions and bruises!

- ▶ Never stand under suspended loads.
 - ▶ Wear safety shoes.
 - ▶ Secure drive converter accordingly when using lifting gear.
-

- To prevent damages to the device:
- Make sure that no components are bent and/or isolation distances are changed.
- The device must not be put into operation in case of mechanical defects. Non-compliance with the applicable standards.
- Do not allow moisture or mist to penetrate the unit.
- Avoid dust permeating the device. Allow for sufficient heat dissipation if installed in a dust-proof housing.
- Note installation position and minimum distances to surrounding elements. Do not cover the ventilation openings.
- Mount the drive inverter according to the specified degree of protection.
- Make sure that no small parts fall into the COMBIVERT during assembly and wiring (drilling chips, screws etc.). This also applies to mechanical components, which can lose small parts during operation.
- Check the reliable fit of the device connections in order to avoid contact resistances and sparking.
- Do not walk-on drive converter.
- The safety instructions are to be kept!

1.4 Electrical connection

⚠ DANGER



Voltage at the terminals and in the device !

Danger to life due to electric shock !

- ▶ Never work on the open device or never touch exposed parts.
- ▶ For any work on the unit switch off the supply voltage, secure it against switching on and check absence of voltage by measurement.
- ▶ Wait until all drives has been stopped in order that no regenerative energy can be generated.
- ▶ Await capacitor discharge time (5 minutes) if necessary, measure DC voltage at the terminals.
- ▶ If personal protection is required, install suitable protective devices for drive converters.
- ▶ Never bridge upstream protective devices (also not for test purposes).
- ▶ Connect the protective earth conductor always to drive converter and motor.
- ▶ Install all required covers and protective devices for operation.
- ▶ The control cabinet shall be kept closed during operation.
- ▶ Residual current: This product may cause a dc current in the protective earth conductor. When a residual current protective device (RCD) or a residual current monitoring device (RCM) is used for the protection against direct or indirect contact, only a RCD or RCM type B is permitted on the power supply side of this product.
- ▶ Drive converters with a leakage current > 3.5mA AC current (10mA DC current) are intended for a stationary connection. Protective earth conductors must be designed in accordance with the local regulations for equipment with high leakage currents according to [EN 61800-5-1](#), [EN 60204-1](#) or [DIN IEC 60364-5-54](#) .



If personnel protection is required during installation of the system, suitable protective devices must be used for drive converters.

www.keb.de/fileadmin/media/Manuals/knowledge/04_techinfo/00_general/ti_rcd_0400_0002_gbr.pdf



Installations which include drive converter shall be equipped with additional control and protective devices in accordance with the relevant applicable safety requirements, e.g. act respecting technical equipment, accident prevention rules etc. They must always be complied with, also for drive converter bearing a CE marking.

For a trouble-free and safe operation, please pay attention to the following instructions:

- The electrical installation shall be carried out in accordance with the relevant requirements.
- Cable cross-sections and fuses must be dimensioned by the user according to the specified minimum/maximum values for the application.
- The wiring must be made with flexible copper cable for a temperature > 75°C.
- Connection of the drive converter is only permissible on symmetrical networks with a maximum line voltage (L1, L2, L3) with respect to earth (N/PE) of max. 300 V. An isolating transformer must be used for supply networks which exceed this value! In case of non-compliance the control is not longer considered to be a PELV circuit.
- With existing or newly wired circuits the person installing the units or machines must ensure that the PELV requirements are met.
- For drive converters that are not isolated from the supply circuit (in accordance with [EN 60721-3-2](#)) all control lines must be included in other protective measures (e.g. double insulation or shielded, earthed and insulated).
- When using components without isolated inputs/outputs, it is necessary that equipotential bonding exists between the components to be connected (e.g. by the equipotential line). Disregard can cause destruction of the components by equalizing currents.

1.4.1 EMC-compatible installation

Observance of the limit values required by EMC law is the responsibility of the customer.



Notes on EMC-compatible installation can be found here.
www.keb.de/fileadmin/media/Manuals/emv/0000neb0000.pdf



1.4.2 Voltage test

Testing with AC voltage (in accordance with [EN 60204-1](#) chapter 18.4) may not be executed, since there is danger for the power semiconductors in the drive inverter.



Due to the radio interference suppression capacitors, the test generator will switch off immediately with a current fault.



According to [EN 60204-1](#) it is permissible to disconnect already tested components. Drive converters of the KEB Automation KG are delivered ex works voltage tested to 100% according to product standard.

1.4.3 Insulation measurement

An insulation measurement (in accordance with [EN 60204-1](#) chapter 18.3) with DC 500 V is permissible, if all power unit connections (grid-connected potential) and all control connections are bridged with PE. The insulation resistance of the respective device can be found in the technical data.

1.5 Start-up and operation

The drive converter must not be started until it is determined that the installation complies with the machine directive; Account is to be taken of [EN 60204-1](#).

⚠ WARNING

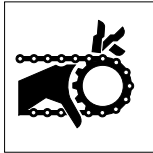

Software protection and programming!

Hazards caused by unintentional behavior of the drive!

- ▶ Check especially during initial start-up or replacement of the drive converter if parameterization is compatible to application.
- ▶ Securing a unit solely with software-supported functions is not sufficient. It is imperative to install external protective measures (e.g. limit switch) that are independent of the drive converter.
- ▶ Secure motors against automatic restart.

⚠ CAUTION



High temperatures at heat sink and coolant!

Burning of the skin!

- ▶ Cover hot surfaces safe-to-touch.
- ▶ If necessary, attach warning signs on the system.
- ▶ Before touching, check the surface and coolant lines.
- ▶ Before working let the unit cool down.

- During operation, all covers and doors shall be kept closed.
- Use only approved accessories for this device.
- Never touch terminals, busbars or cable ends.



If a drive converter with electrolytic capacitors in a DC link (see technical data) has not been in operation for more than one year, observe the following instructions.

www.keb.de/fileadmin/media/Manuals/knowledge/04_techinfo/00_general/ti_format_capacitors_0400_0001_gbr.pdf



NOTICE

Continuous operation (S1) with load > 60% or from a rated motor power of 55 kW!

Premature ageing of the electrolytic capacitors!

- ▶ Mains choke with $U_k = 4\%$ absolutely necessary.

Switching at the output

Switching between motor and drive converter is prohibited for single drives during operation as this may trigger the protection gear of the device. Function ‚speed search‘ must be activated if switching can not be avoided. Speed search may only be triggered after closing the motor contactor (e.g. by switching the control release).

Connecting and disconnecting is permissible with multiple motor drives if at least 1 motor is running during the switch-over process. The drive converter must be dimensioned to the occurring starting currents.

The ‚speed search‘ function must be activated if the motor is still running during a restart of the drive converter (mains on) (e.g. due to large rotating masses).

Switching an the input

For applications that require cyclic switching off and on of the drive converter, maintain an off-time of at least 5 min after the last switch on. If you require shorter cycle times please contact KEB Automation KG.

Short-circuit resistance

The drive converters are conditional short-circuit proof. After resetting the internal protection devices, the function as directed is guaranteed.

Exceptions:

- If an earth-leakage fault or short-circuit often occurs at the output, this can lead to a defect in the unit.
- If a short-circuit occurs during regenerative operation (2nd or 4th quadrant, regeneration into the DC link), this can lead to a defect in the unit.

1.6 Maintenance

The following maintenance work has to be carried out when required, but at least once per year by authorized and trained personnel. Check unit for loose screws and plugs and tighten if necessary.

- ▶ Check system for loose screws and plugs and tighten if necessary.
- ▶ Clean drive converter from dirt and dust deposits. Pay attention especially to cooling fins and protective grid of the fans.
- ▶ Examine and clean extracted air filter and cooling air filter of the control cabinet.
- ▶ Check the function of the fans of the drive converter. The fan must be replaced in case of audible vibrations or squeak.
- ▶ In the case of liquid-cooled drive converters a visual test of the cooling circuit for leaks and corrosion must be carried out. The cooling circuit must be completely empty if a unit shall be switched off for a longer period. The cooling circuit must be blown out additionally with compressed air at temperatures below 0°C.

1.8 Repair

In case of malfunction, unusual noises or smells inform a person in charge!

DANGER



Unauthorized exchange, repair and modifications!

Unpredictable malfunctions!

- ▶ The function of the drive converter is dependent on its parameterization. Never replace without knowledge of the application.
- ▶ Modification or repair is permitted only by KEB Automation KG authorized personnel.
- ▶ Only use original manufacturer parts.
- ▶ Infringement will annul the liability for resulting consequences.

In case of failure, please contact the machine manufacturer. Only the machine manufacturer knows the parameterisation of the used drive converter and can provide an appropriate replacement or induce the maintenance.

1.7 Disposal

Electronic devices of the KEB Automation KG are exclusively professional devices for further industrial processing (so-called B2B devices).

Manufacturers of B2B devices are obliged to take back and recycle devices manufactured after 14.08.2018. These devices may not be disposed at the collection centres of public sector disposal organisations.



If no deviating agreement has been made between the customer and KEB or no deviating mandatory legal regulation exists, KEB products marked in this way can be returned. Company and keyword to the return point can be taken from the list below. Shipping costs are paid by the customer. Thereupon the devices will be professionally recycled and disposed.

The entry numbers are listed country-specific in the following table. The corresponding KEB return addresses can be found on our website.

Withdrawal by	WEEE-Reg.-No.	Keyword
Austria		
KEB Automation GmbH	ERA: 51976	Stichwort „Rücknahme WEEE“
France		
RÉCYLUM - Recycle point	ADEME: FR021806	Mots clés „KEB DEEE“
Germany		
KEB Automation KG	EAR: DE12653519	Stichwort „Rücknahme WEEE“
Italy		
COBAT	AEE: (IT) 19030000011216	Parola chiave „Ritiro RAEE“
Spain		
KEB Automation KG	RII-AEE 7427	Palabra clave „Retirada RAEE“

The packaging must be feed to paper and cardboard recycling.

2 Product Description

The COMBIVERT F6 device series concerns to drive converters, which are optimized for operation at synchronous and asynchronous motors. The COMBIVERT can be extended with a safety module for the use in safety-oriented applications. It can be operated with a fieldbus module at different fieldbus systems. The control board has a system comprehensive operating concept.

The COMBIVERT meets the requirements of the Low-Voltage Directive. The harmonized standards of the series [EN 61800-5-1](#) for drive converter were used.

The COMBIVERT is a product of limited availability in accordance with [EN 61800-3](#). This product may cause radio interference in residential areas. In this case the operator may need to take corresponding measures.

The machine directive, EMC directive, Low Voltage Directive and other guidelines and regulations must be observed depending on the version.

2.1 Specified application

The COMBIVERT serves exclusively for the control and regulation of three-phase motors. It is intended for the installation into electrical systems or machines.

Technical data and information for connection conditions shall be taken from the nameplate and from the instructions for use and must be strictly observed.

The used semiconductors and components of the KEB Automation KG are developed and dimensioned for the use in industrial products.

Restriction

If the product is used in machines, which work under exceptional conditions or if essential functions, life-supporting measures or an extraordinary safety step must be fulfilled, the necessary reliability and security must be ensured by the machine builder.

2.1.1 Residual risks

Despite intended use, the drive converter can reach unexpected operating conditions in case of error, with wrong parameterization, by faulty connection or unprofessional interventions and repairs. This can be:

- wrong direction of rotation
- motor speed too high
- motor is running into limitation
- motor can be under voltage even in standstill
- automatic start

2.2 Unintended use

The operation of other electric consumers is prohibited and can lead to the destruction of the devices. The operation of our products outside the indicated limit values of the technical data leads to the loss of any liability claims.

2.3 Product features

These instructions for use describe the power units of the following devices:

Device type:	Drive converter
Series:	COMBIVERT F6
Power range:	22 kW / 230 V 22...55 kW / 400 V
Housing:	4



The COMBIVERT F6 is characterized by the following features:

- Operation of three-phase asynchronous motors and three-phase synchronous motors, in operating modes open-loop or closed-loop with and without speed feedback
- Following fieldbus systems are supported: EtherCAT, VARAN, PROFINET, POWERLINK or CAN
- System-overlapping operating concept
- Wide operating temperature range
- Low switching losses by IGBT power unit
- Low noise development due to high switching frequencies
- Different heat sink concepts
- Temperature-controlled fan, easily replaceable
- Torque limits and s-curves are adjustable to protect gearboxes
- General protection functions of the COMBIVERT series against overcurrent, over-voltage, ground fault and overtemperature
- Analog inputs and outputs, digital inputs and outputs, relay output (potential-free), brake control and -supply, motor protection by I²t, KTY- or PTC input, two encoder interfaces, diagnostic interface, fieldbus interface (depending on the control board)
- Integrated safety function according to [EN 61800-5-2](#)

2.4 Part code

x x	F 6	x	x	x	-x	x	x	x																																		
								Heat sink version		1: Air-cooler, mounted version																																
										2: Liquid cooler (water), mounted version																																
										3: Air-cooler, through-mount version IP54																																
										4: Liquid cooler (water), through-mount version IP54																																
										5: Air-cooler, through-mount version IP20																																
										6: Liquid cooler (water), trough-mount version IP54, sub-mounted braking resistors																																
										7: Liquid cooler (oil), through-mount version IP54																																
										9: Liquid cooler (water), mounted version, sub-mounted braking resistors																																
										A: Liquid cooler (water), trough-mount version IP54, sub-mounted braking resistors version 2																																
										B: Liquid cooler (water), mounted version, sub-mounted braking resistors version 2																																
																Control board variant		APPLIKATION																								
																		1: Multi Encoder Interface, CAN ^{® 2)} , Real-Time Ethernet-busmodule ³⁾																								
																										KOMPAKT																
		1: Multi Encoder Interface, CAN ^{® 2)} , STO, EtherCAT ^{® 1)}																																								
		2: Multi Encoder Interface, CAN ^{® 2)} , STO, VARAN																																								
																										PRO																
																										3: Multi Encoder Interface, CAN ^{® 2)} , Real-Time Ethernet interface ³⁾ , RD485-potential free																
																										4: No Encoder, CAN ^{® 2)} , Real-Time Ethernetinterface ³⁾ , safe relay																
																										5: Multi Encoder Interface, CAN ^{® 2)} , Real-Time Ethernet interface ³⁾ , Safety Relay																
																																Switching frequency, Software current limit, Turn-off current		0: 2 kHz / 125% / 150%								
																																		6: 8 kHz / 150% / 180%								
																																		1: 4 kHz / 125% / 150%								
																																		7: 16 kHz / 150% / 180%								
										2: 8 kHz / 125% / 150%																																
										8: 2 kHz / 180% / 216%																																
										3: 16 kHz / 125% / 150%																																
										9: 4 kHz / 180% / 216%																																
										4: 2 kHz / 150% / 180%																																
		A: 8 kHz / 180% / 216%																																								
		5: 4 kHz / 150% / 180%																																								
		B: 16 kHz / 180% / 216%																																								
								Voltage / Connection type		1: 3ph 230V AC/DC with braking transistor																																
										2: 3ph 230V AC/DC without braking transistor																																
										3: 3ph 400V AC/DC with braking transistor																																
										4: 3ph 400V AC/DC without braking transistor																																
																Housing		2...9																								
																								Control type		1: Safety module type 1 /STO at control type K																
																										3: Safety module type 3																
																										4: Safety module type 4																
																										5: Safety module type 5																
																																		A: APPLICATION								
																																		K: COMPACT								
																																		P: PRO								
																																								Series		COMBIVERT F6
																																								Inverter size		10...33

Table 1: Part code

- 1)  *EtherCAT® is registered trademark and patented technology, licensed by Beckhoff Automation GmbH, Germany*
- 2)  *CANopen® is registered trademark of CAN in AUTOMATION - International Users and Manufacturers Group e.V.*
- 3) *The Real-Time Ethernetbusmodul / Real-Time Ethernet interface contains various fieldbus control types which can be adjusted by software (parameter fb68)*



The part code may not be used as order code, but only for identification!

2.5 Nameplate

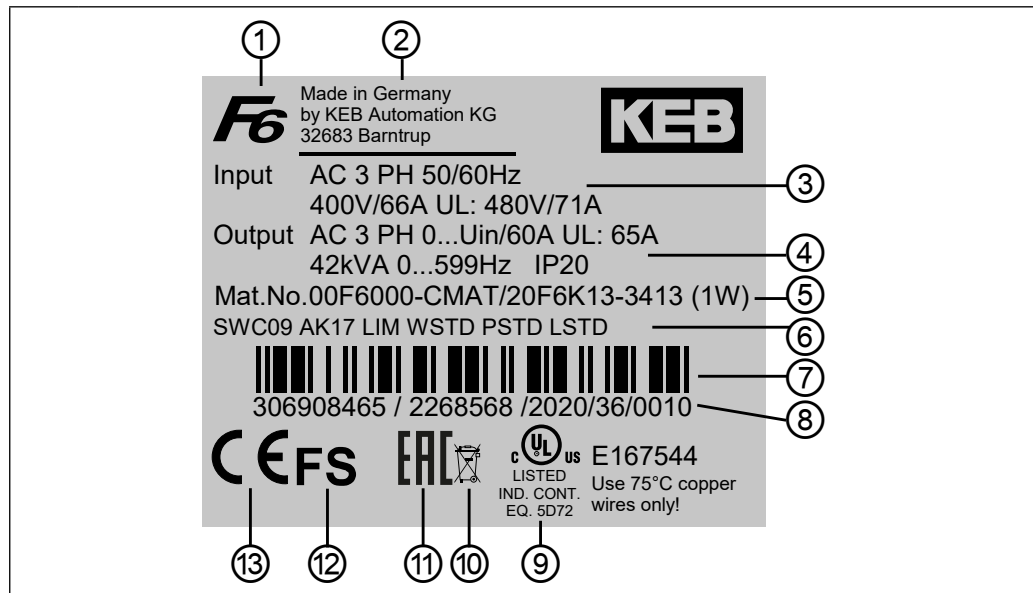

Legend	
1	Device series
2	Manufacturer identification
3	Technical data input
4	Technical data output
5	Material number, basic device => „1.5 Nameplate“, version number
6	Configurable options or customer material number/version => „1.5.1 Configurable options“
7	Barcode Interleaved 2/5 (serial number)
8	Serial-, order number; Year and week of production; Factory
9	UL certification
10	Disposal information
11	EAC certification
12	FS certification
13	CE certification

Figure 1: Nameplate

2.5.1 Configurable options

Features	Feature values	Description
Software	SWxxx	Software status of the drive converter
Accessories	Axxx	Selected accessories
	NAK	No accessories
Output frequency activation	LIM	Limitation to 599 Hz
	ULO	> 599Hz activated
Warranty	WSTD	Warranty - Standard
	Wxxx	Warranty extension
Parameterization	PSTD	Parameterization - Standard
	Pxxx	Parameterization - Customer-specific
Nameplate logo	LSTD	Logo - Standard
	Lxxx	Logo - Customer-specific
<i>Figure 2: Configurable options</i>		

„x“ indicates a variable value

3 Technical Data

Unless otherwise indicated, all electrical data in the following chapter refer to a 3-phase AC mains.

3.1 Operating conditions

3.1.1 Climatic environmental conditions

Storage		Standard	Class	Descriptions
Ambient temperature		EN 60721-3-1	1K4	-25...55 °C
Relative humidity		EN 60721-3-1	1K3	5...95 % (without condensation)
Storage height		–	–	Max. 3000 m above sea level
Transport		Standard	Class	Descriptions
Ambient temperature		EN 60721-3-2	2K3	-25...70 °C
Relative humidity		EN 60721-3-2	2K3	95 % at 40 °C (without condensation)
Operation		Standard	Class	Descriptions
Ambient temperature		EN 60721-3-3	3K3	5...40 °C (extended to -10...45 °C)
Coolant inlet temperature	Air	–	–	5...40 °C (-10...45 °C)
	Water	–	–	5...40 °C
	Oil	–	–	40...55 °C
Relative humidity		EN 60721-3-3	3K3	5...85 % (without condensation)
Version and degree of protection		EN 60529	IP20	Protection against foreign material > ø12.5 mm No protection against water Non-conductive pollution, occasional condensation when PDS is out of service. Drive converter generally, except power connections and fan unit (IPxxA)
Site altitude		–	–	Max. 2000 m above sea level <ul style="list-style-type: none"> • With site altitudes over 1000 m a derating of 1 % per 100 m must be taken into consideration. • With site altitudes over 2000 m, the control board to the mains has only basic isolation. Additional measures must be taken when wiring the control.

Table 2: Climatic environmental conditions

3.1.2 Mechanical environmental conditions

Storage	Standard	Class	Descriptions
Vibration limits	<i>EN 60721-3-1</i>	1M2	Vibration amplitude 1.5 mm (2...9Hz) Acceleration amplitude 5 m/s ² (9...200Hz)
Shock limit values	<i>EN 60721-3-1</i>	1M2	40 m/s ² ; 22 ms
Transport	Standard	Class	Descriptions
Vibration limits	<i>EN 60721-3-2</i>	2M1	Vibration amplitude 3.5 mm (2...9Hz) Acceleration amplitude 10 m/s ² (9...200 Hz) (Acceleration amplitude 15 m/s ² (200...500Hz))*
Shock limit values	<i>EN 60721-3-2</i>	2M1	100 m/s ² ; 11 ms
Operation	Standard	Class	Descriptions
Vibration limits	<i>EN 60721-3-3</i>	3M4	Vibration amplitude 3.0 mm (2...9Hz) Acceleration amplitude 10 m/s ² (9...200 Hz)
	<i>EN 61800-5-1</i>	–	Vibration amplitude 0.075 mm (10...57 Hz) Acceleration amplitude 10 m/s ² (57...150 Hz)
Shock limit values	<i>EN 60721-3-3</i>	3M4	100 m/s ² ; 11 ms
Pressure in the water cooler	–	–	Rated operating pressure: 10 bar Max. operating pressure: 10 bar

Table 3: Mechanical environmental conditions

*Not tested

3.1.3 Chemical / mechanical active substances

Storage	Standard	Class	Descriptions	
Contamination	<i>EN 60721-3-1</i>	Gases	1C2	–
		Solids	1S2	–
Transport	Standard	Class	Descriptions	
Contamination	<i>EN 60721-3-2</i>	Gases	2C2	–
		Solids	2S2	–
Operation	Standard	Class	Descriptions	
Contamination	<i>EN 60721-3-3</i>	Gases	3C2	–
		Solids	3S2	–

Table 4: Chemical / mechanical active substances

3.1.4 Electrical operating conditions

3.1.4.1 Device classification

Requirement	Standard	Class	Descriptions
Overvoltage category	EN 61800-5-1	III	–
	EN 60664-1		–
Pollution degree	EN 60664-1	2	Non-conductive pollution, occasional condensation when PDS is out of service.

Table 5: Device classification

3.1.4.2 Electromagnetic compatibility

For devices without an internal filter, an external filter is required to comply with the following limits.

EMC emitted interference	Standard	Class	Descriptions
Line-conducted interferences	EN 61800-3	C2	–
Radiated interferences	EN 61800-3	C2	–
Immunity	Standard	Level	Descriptions
Static discharges	EN 61000-4-2	8 kV 4 kV	AD (air discharge) CD (contact discharge)
Burst - Ports for process measurement control lines and signal interfaces	EN 61000-4-4	2 kV	–
Burst - Power ports	EN 61000-4-4	4 kV	–
Surge - Power ports	EN 61000-4-5	1 kV 2 kV	Phase-phase Phase-ground
Immunity to conducted disturbances, induced by high-frequency fields	EN 61000-4-6	10 V	0.15...80 MHz
Electromagnetic fields	EN 61000-4-3	10 V/m 3 V/m 1 V/m	80 MHz...1 GHz 1.4...2 GHz 2...2.7 GHz
Voltage fluctuations/ voltage dips	EN 61000-2-1 EN 61000-4-34	–	-15 %...+10 % 90 %
Frequency changes	EN 61000-2-4	–	≤ 2 %
Voltage deviations	EN 61000-2-4	–	±10 %
Voltage unbalance	EN 61000-2-4	–	≤ 3 %

Table 6: Electromagnetic compatibility

3.2 Device data of the 230V devices

3.2.1 Overview of the 230V devices

The technical data are for 2/4-pole standard motors. With other pole numbers the drive converter must be dimensioned onto the rated motor current. Contact KEB for special or medium frequency motors.

Device size		18
Housing		4
Rated apparent output power	S_{out} / kVA	34
Max. rated motor power	³⁾ P_{mot} / kW	22
Rated input voltage	U_N / V	230 (UL: 240)
Input voltage range	U_{in} / V	170...264
Mains phases		3
Mains frequency	f_N / Hz	50 / 60 ±2
Rated input current @ $U_N = 230V$	I_{in} / A	101
Rated input current @ $U_N = 240V$	I_{in_UL} / A	101
Insulation resistance @ $U_{dc} = 500V$	R_{iso} / MΩ	> 20
Output voltage	U_{out} / V	0... U_{in}
Output frequency	²⁾ f_{out} / Hz	0...599
Output phases		3
Rated output current @ $U_N = 230V$	I_N / A	85
Rated output current @ $U_N = 240V$	I_{N_UL} / A	85
Rated output overload (60 s)	^{1) 5)} I_{60s} / %	150
Software current limit	¹⁾ I_{lim} / %	150
Overcurrent	¹⁾ I_{OC} / %	180
Rated switching frequency	f_{SN} / kHz	4
Max. switching frequency	⁴⁾ f_{S_max} / kHz	16
Power dissipation at rated operation	³⁾ P_D / W	776
Overload current over time	¹⁾ I_{OL} / %	=> „Overload characteristic (OL) for 230V devices“
Maximum current 0Hz/50Hz at $f_s=2$ kHz	I_{max_out} / %	175 / 180
Maximum current 0Hz/50Hz at $f_s=4$ kHz	I_{max_out} / %	147 / 180
Maximum current 0Hz/50Hz at $f_s=8$ kHz	I_{max_out} / %	110 / 180
<i>continued on the next page</i>		

Device size		18
Housing		4
Maximum current 0Hz/50Hz at $f_s = 16\text{kHz}$	$I_{max_out} / \%$	73 / 128
Max. braking current	I_{B_max} / A	105
Min. braking resistor value	R_{B_min} / Ω	4
Braking transistor (GTR7)	⁶⁾	Max. cycle time: 120 s; ED: 50 %
Protection function for braking transistor (GTR7)		Short-circuit monitoring
Protective function braking resistor (Error GTR7 always on)	⁷⁾	Feedback signal evaluation and current shutdown
Table 7: Overview of the 230V device data		

- ¹⁾ The values refer in % to the rated output current I_N .
- ²⁾ The output frequency is to be limited in such a way that it does not exceed 1/10 of the switching frequency. Devices with higher max. output frequency are subject to export restrictions and are only available on request.
- ³⁾ Rated operation corresponds to $U_N = 230\text{V}$, rated switching frequency, output frequency = 50 Hz (4-pole standard asynchronous motor).
- ⁴⁾ A detailed description of the Derating => „Switching frequency and temperature“.
- ⁵⁾ Observe limitations => „Overload characteristic (OL) for 230V devices“.
- ⁶⁾ The cyclic duration factor is additionally limited by the used braking resistor.
- ⁷⁾ The feedback signal evaluation monitors the functionality of the braking transistor (GTR7). Power off occurs via the internal mains input bridge of the AC supply.

3.2.2 Voltage and frequencies for 230V devices

Input voltages and frequencies		
Rated input voltage	U_N / V	230
Rated mains voltage (USA)	U_{N_UL} / V	240
Input voltage range	U_{IN} / V	170...264
Input phases		3
Mains frequency	f_N / Hz	50/60
Mains frequency tolerance	$\pm f_N / \text{Hz}$	2
Table 8: Input voltages and frequencies of the 230V devices		

DC link voltage		
DC link rated voltage @ $U_N = 400\text{V}$	U_{N_dc} / V	325
DC link rated voltage @ $U_{N_UL} = 480\text{V}$	$U_{N_UL_dc} / \text{V}$	339
DC link voltage working voltage range	U_{IN_dc} / V	240...373
Table 9: DC link voltage for 230V devices		

Output voltages and frequencies		
Output voltage at AC supply	¹⁾ U_{out} / V	0... U_{in}
Output frequency	²⁾ f_{out} / Hz	0...599
Output phase		3

Table 10: Output voltages and frequencies of the 230V devices

- ¹⁾ The voltage to the motor is dependent on the actual input voltage and the control method („Example of the calculation of the possible motor voltage 230V:“).
- ²⁾ The output frequency is to be limited in such a way that it does not exceed 1/10 of the switching frequency. Devices with higher max. output frequency are subject to export restrictions and are only available on request.

3.2.2.1 Example of the calculation of the possible motor voltage 230V:

The motor voltage for dimensioning of the drive is depending on the used components. The motor voltage reduces according to the following table:

Component	Reduction / %	Example
Mains choke U_k	4	Example: open-loop drive converter with mains- and motor choke at non-rigid supply system: 230 V mains voltage - 11 % = 204,7 V motor voltage
Drive converter open-loop	4	
Drive converter closed-loop	8	
Motor choke U_k	1	
Non-rigid supply system	2	

Table 11: Example of the calculation of the possible motor voltage 230V:

3.2.3 Input and output currents / overload for 230V devices

Device size		18
Rated input current @ $U_N = 230V$	¹⁾ I_{in} / A	101
Rated input current @ $U_{N_UL} = 240V$	¹⁾ I_{in_UL} / A	101

Table 12: Input currents of the 230V devices

- ¹⁾ The values resulting from rated operation with B6 rectifier circuit and mains choke 4% U_k .

Device size		18
Rated output current @ $U_N = 230V$	I_N / A	85
Rated output current @ $U_{N_UL} = 240V$	I_{N_UL} / A	85
Rated output overload (60 s)	¹⁾ $I_{60s} / \%$	150
Overload current	¹⁾ $I_{OL} / \%$	=> „Overload characteristic (OL) for 230V devices“
Software current limit	¹⁾²⁾ $I_{lim} / \%$	150
Overcurrent	¹⁾ $I_{oc} / \%$	180

Table 13: Output currents 230V devices

- ¹⁾ The values refer in % to the rated output current I_N .
- ²⁾ Limitation of the current setpoint in closed-loop operation. This setpoint limit is not active in v/f operation.

3.2.3.1 Overload characteristic (OL) for 230V devices

All drive converters can be operated at rated switching frequency with an utilization of 150 % for 60s.

Restrictions:

- The thermal design of the heat sink is based on the rated operation. The following values are taken into account: Rated output current, ambient temperature, rated switching frequency, rated voltage.
- At high surrounding temperatures and/or high heat sink temperatures (for example, by preceding utilization nearby 100%) the drive converter can change to overtemperature error before triggering the protective function OL.
- At low output frequencies or switching frequencies higher than the rated switching frequency, the frequency-dependent maximum current can be exceeded before and error OL2 can be triggered => „*Frequency-dependent maximum current (OL2) for 230V devices*“.

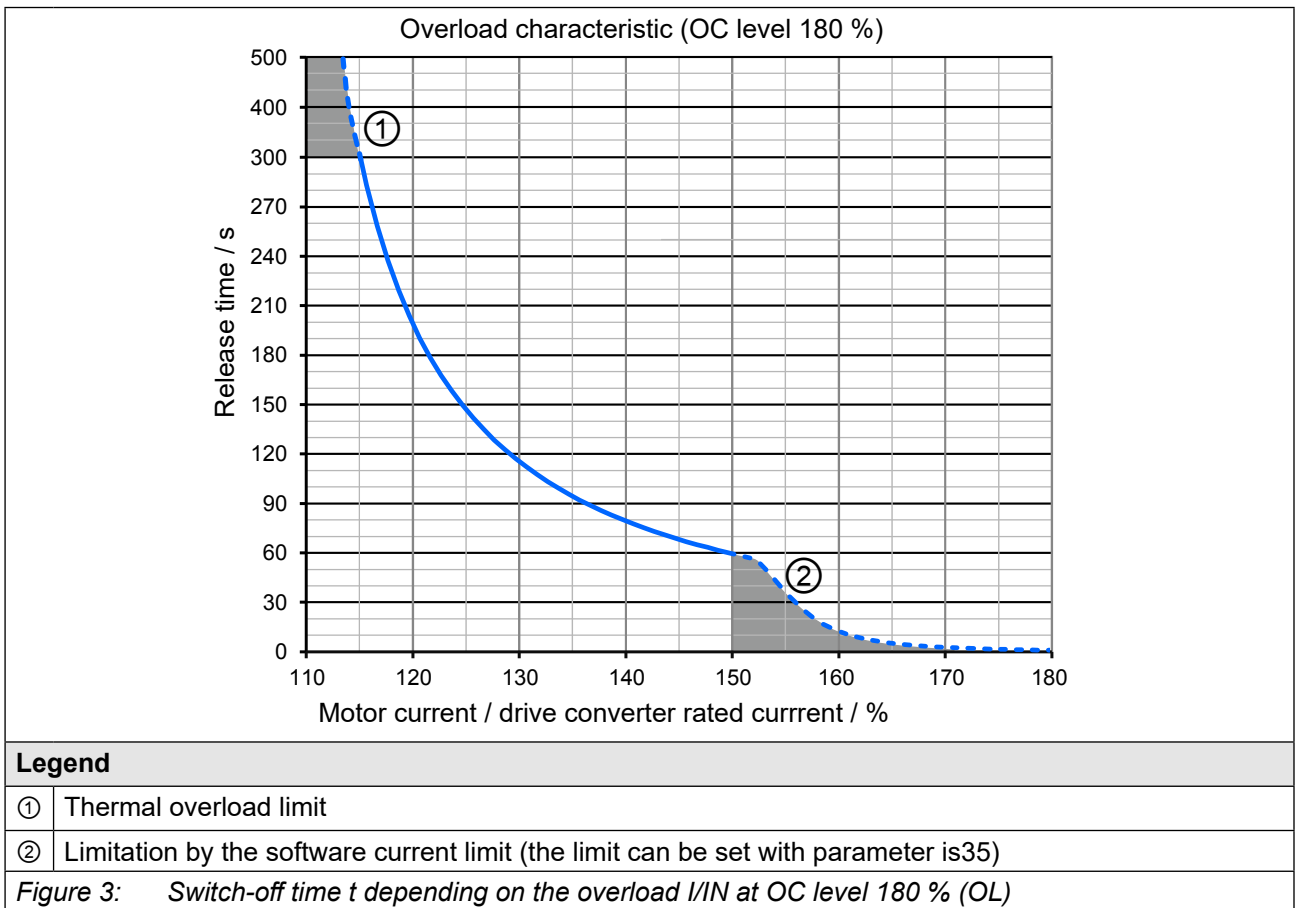

- On exceeding a load of 105 % the overload integrator starts.
- When falling below the integrator counts backwards.
- If the integrator reaches the overload characteristic „Error! overload (OL)“ is triggered.

After a cooling down period, the integrator can be reset now. The drive converter must remain switched on during the cooling down phase.

Operation in the range of the thermal overload limit

Due to the high slope of the overload characteristic, the duration of a permissible overload in range □ cannot be determined exactly. Therefore, the design of the drive converter should be assumed to have a maximum overload time of 300s.

3.2.3.2 Frequency-dependent maximum current (OL2) for 230V devices

The characteristics of the maximum currents for a switching frequency which are depending on the output frequency are different for each drive converter, but the following rules are generally applicable:

- Applies for the rated switching frequency: At 0 Hz output frequency the drive converter can provide at least the rated output current.
- Lower maximum currents apply for switching frequencies > rated switching frequency.

If error (OL2) shall be triggered on exceeding the maximum currents or if the switching frequency is automatically reduced (derating) can be adjusted in the drive converter parameters.

The following characteristic curve indicates the permissible maximum current for the output frequency values 0 Hz, 3 Hz, 6 Hz, 10 Hz, 25 Hz and 50 Hz. If there is a deviation of the shown switching frequencies, it will be interpolated between the characteristics. Device size 18 is shown as an example.

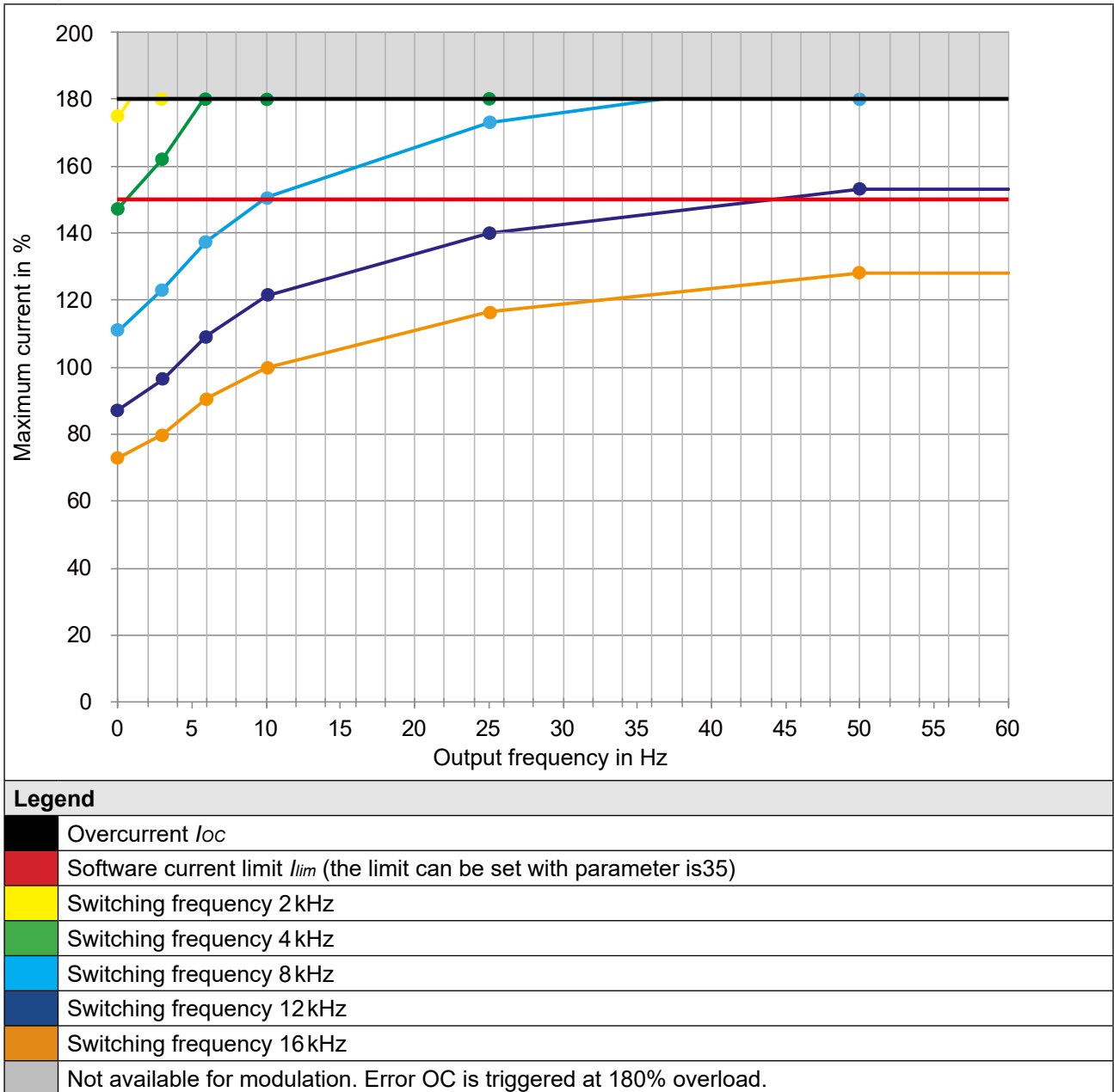

Figure 4: Typical overload characteristics in the lower output frequencies (OL2) Example. Device size 18



The frequency-dependent maximum current I_{lim} refers in % to the rated output current I_N .

The current remains constant from the last specified output frequency value.



The values for the respective device size are listed in the following tables.

Frequency-dependent maximum current

Device size		18					
Rated switching frequency		4 kHz					
Output frequency	f_{out} / Hz	0	3	6	10	25	50
Frequency-dependent maximum current @ f_s <i>Basic Time Period = 62.5 μs (Parameter is22=0)</i>	2 kHz	175	180	180	180	180	180
	4 kHz	147	162	180	180	180	180
	8 kHz	111	124	138	151	173	180
	16 kHz	73	80	91	100	117	128
Frequency-dependent maximum current @ f_s <i>Basic Time Period = 71.4 μs (Parameter is22=1)</i>	1.75 kHz	175	180	180	180	180	180
	3.5 kHz	154	171	180	180	180	180
	7 kHz	120	133	149	162	180	180
	14 kHz	80	88	100	111	128	141
Frequency-dependent maximum current @ f_s <i>Basic Time Period = 83.3 μs (Parameter is22=2)</i>	1.5 kHz	175	180	180	180	180	180
	3 kHz	161	179	180	180	180	180
	6 kHz	129	143	159	174	180	180
	12 kHz	87	96	109	121	140	153
Frequency-dependent maximum current @ f_s <i>Basic Time Period = 100 μs (Parameter is22=3)</i>	1.25 kHz	175	180	180	180	180	180
	2.5 kHz	168	180	180	180	180	180
	5 kHz	138	153	170	180	180	180
	10 kHz	99	110	124	136	157	171

Table 14: Frequency-dependent maximum current for device size 18

3.2.4 Power dissipation at rated operation for 230V devices

Device size	18
Power dissipation at rated operation ¹⁾ P_D / W	776

Table 15: Power dissipation of the 230V devices

¹⁾ Rated operation corresponds to $U_N = 230\text{ V}$; f_{SN} ; I_N ; $f_N = 50\text{ Hz}$ (typically value)

3.2.5 Fuse protection of the drive converters for 230V devices

Device size	Max. size of the fuse / A			
	$U_N = 230V$ gG (IEC)	$U_N = 240V$ Class „J“	$U_N = 240V$ gR	
	SCCR 30 kA	SCCR 5 kA	SCCR 30 kA	Type
18	125	110	125	SIBA 20 189 20.125 EATON 170M1368

Table 16: Fusing of the 230 V / 240 V devices



Short-circuit capacity

After requests from [EN 60439-1](#) and [EN 61800-5-1](#) the following is valid for the connection to a network: The devices are suitable for use in a circuit capable of delivering not more than 30 kA eff. unaffected symmetrical short-circuit current.

3.3 Device data of the 400V devices

3.3.1 Overview of the 400V devices

The technical data are for 2/4-pole standard motors. With other pole numbers the drive converter must be dimensioned onto the rated motor current. Contact KEB for special or medium frequency motors.

Device size		18 ⁸⁾	19	20	21	22
Housing		4				
Rated apparent output power	S_{out} / kVA	35	42	52	62	76
Max. rated motor power	³⁾ P_{mot} / kW	22	30	37	45	55
Rated input voltage	U_N / V	400 (UL: 480)				
Input voltage range	U_{in} / V	280...550				
Mains phases		3				
Mains frequency	f_N / Hz	50 / 60 ±2				
Rated input current @ $U_N = 400V$	I_{in} / A	59	66	82	99	121
Rated input current @ $U_N = 480V$	I_{in_UL} / A	48	57	71	85	106
Insulation resistance @ $U_{dc} = 500V$	R_{iso} / MΩ	> 20				
Output voltage	U_{out} / V	0... U_{in}				
Output frequency	²⁾ f_{out} / Hz	0...599				
Output phases		3				
Rated output current @ $U_N = 400V$	I_N / A	50	60	75	90	110
Rated output current @ $U_N = 480V$	I_{N_UL} / A	40	52	65	77	96
Rated output overload (60 s)	^{1) 5)} I_{60s} / %	150				
Software current limit	¹⁾ I_{lim} / %	150				
Overcurrent	¹⁾ I_{OC} / %	180				
Rated switching frequency	f_{SN} / kHz	4	4	4	2	2
Max. switching frequency	⁴⁾ f_{s_max} / kHz	16				
Power dissipation at rated operation	³⁾ P_D / W	513	698	896	895	1082
Overload current over time	¹⁾ I_{OL} / %	=> „Overload characteristic (OL) for 400 V devices“				
Maximum current 0Hz/50Hz at $f_s = 2$ kHz	I_{max_out} / %	180/180	176/180	141/180	117/180	111/180
Maximum current 0Hz/50Hz at $f_s = 4$ kHz	I_{max_out} / %	162/180	135/180	108/180	90/153	82/138

continued on the next page

Device size	18 ⁸⁾	19	20	21	22
Housing	4				
Maximum current 0Hz/50Hz at $f_s=8\text{ kHz}$ $I_{max_out} / \%$	106/180	88/156	70/125	58/104	51/93
Maximum current 0Hz/50Hz at $f_s=16\text{ kHz}$ $I_{max_out} / \%$	56/104	46/86	37/69	31/57	24/47
Max. braking current I_{B_max} / A	93				105
Min. braking resistor value R_{B_min} / Ω	9				8
Braking transistor (GTR7) ⁶⁾	Max. cycle time: 120 s; ED: 50 %				
Protection function for braking transistor (GTR7)	Short-circuit monitoring				
Protective function braking resistor (Error GTR7 always on) ⁷⁾	Feedback signal evaluation and current shutdown				

Table 17: Overview of the 400 V device data

- ¹⁾ The values refer in % to the rated output current I_N .
- ²⁾ The output frequency is to be limited in such a way that it does not exceed 1/10 of the switching frequency. Devices with higher max. output frequency are subject to export restrictions and are only available on request.
- ³⁾ Rated operation corresponds to $U_N = 400V$, rated switching frequency, output frequency = 50Hz (4-pole standard asynchronous motor).
- ⁴⁾ A detailed description of the Derating => „Switching frequency and temperature“.
- ⁵⁾ Observe limitations => „Overload characteristic (OL) for 400 V devices“.+
- ⁶⁾ The cyclic duration factor is additionally limited by the used braking resistor.

3.3.2 Voltage and frequencies for 400V devices

From the frequency range of all 400V devices the functionality of the braking transistor (GTR7). Power off occurs via the internal mains input bridge of the AC supply.

Input voltages and frequencies		
Rated input voltage	U_N / V	400
Rated mains voltage (USA)	U_{N_UL} / V	480
Input voltage range	U_{IN} / V	280...550
Input phases		3
Mains frequency	f_N / Hz	50/60
Mains frequency tolerance	$\pm f_N / Hz$	2

Table 18: Input voltages and frequencies of the 400V devices

DC link voltage		
DC link rated voltage @ $U_N = 400V$	U_{N_dc} / V	565
DC link rated voltage @ $U_{N_UL} = 480V$	$U_{N_UL_dc} / V$	680
DC link voltage working voltage range	U_{IN_dc} / V	390...780

Table 19: DC link voltage for 400V devices

Output voltages and frequencies		
Output voltage at AC supply	¹⁾ U_{out} / V	0... U_{N_ac}
Output frequency	²⁾ f_{out} / Hz	0...599
Output phase		3

Table 20: Output voltages and frequencies of the 400V devices

- ¹⁾ The voltage to the motor is dependent on the actual input voltage and the control method („Example of the calculation of the possible motor voltage:“).
- ²⁾ The output frequency is to be limited in such a way that it does not exceed 1/10 of the switching frequency. Devices with higher max. output frequency are subject to export restrictions and are only available on request.

3.3.2.1 Example of the calculation of the possible motor voltage:

The motor voltage for dimensioning of the drive is depending on the used components. The motor voltage reduces according to the following table:

Component	Reduction / %	Example
Mains choke U_k	4	Example: open-loop drive converter with mains- and motor choke at non-rigid supply system: 400 V mains voltage - 11 % = 356 V motor voltage
Drive converter open-loop	4	
Drive converter closed-loop	8	
Motor choke U_k	1	
Non-rigid supply system	2	

Table 21: Example of the calculation of the possible motor voltage:

3.3.3 Input and output currents / overload for 400V devices

Device size		18	19	20	21	22
Rated input current @ $U_N = 400V$	¹⁾ I_{in} / A	59	66	82	99	121
Rated input current @ $U_{N_UL} = 480V$	¹⁾ I_{in_UL} / A	48	57	71	85	106

Table 22: Input currents of the 400 V devices

- ¹⁾ The values resulting from rated operation with B6 rectifier circuit and mains choke 4% U_k .

Device size		18	19	20	21	22
Rated output current @ $U_N = 400V$	I_N / A	50	60	75	90	110
Rated output current @ $U_{N_UL} = 480V$	I_{N_UL} / A	40	52	65	77	96
Rated output overload (60 s)	¹⁾ I_{60s} / %	150				
Overload current	¹⁾ I_{OL} / %	=> „Overload characteristic (OL) for 400 V devices“				
Software current limit	^{1) 2)} I_{lim} / %	150				
Overcurrent	¹⁾ I_{OC} / %	180				

Table 23: Output currents 400 V devices

- ¹⁾ The values refer in % to the rated output current I_N .
- ²⁾ Limitation of the current setpoint in closed-loop operation. This setpoint limit is not active in v/f operation.

3.3.3.1 Overload characteristic (OL) for 400 V devices

All drive converters can be operated at rated switching frequency with an utilization of 150 % for 60s.

Restrictions:

- The thermal design of the heat sink is based on the rated operation. The following values are taken into account: Rated output current, ambient temperature, rated switching frequency, rated voltage.
- At high surrounding temperatures and/or high heat sink temperatures (for example, by preceding utilization nearby 100%) the drive converter can change to overtemperature error before triggering the protective function OL.
- At low output frequencies or switching frequencies higher than the rated switching frequency, the frequency-dependent maximum current can be exceeded before and error OL2 can be triggered => „Overload characteristic (OL) for 400 V devices“.

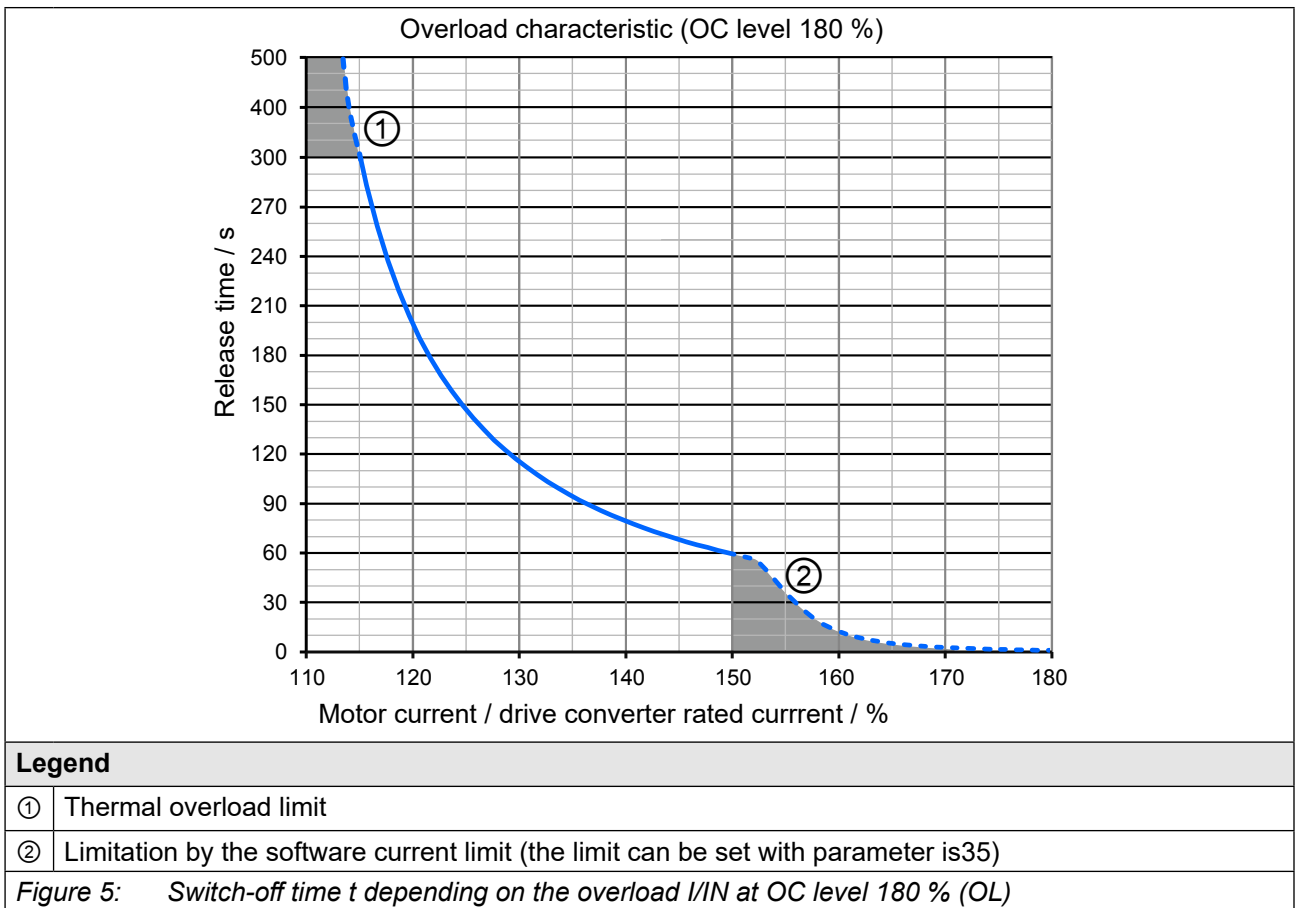

- On exceeding a load of 105 % the overload integrator starts.
- When falling below the integrator counts backwards.
- If the integrator reaches the overload characteristic „Error! overload (OL)“ is triggered.

After a cooling down period, the integrator can be reset now. The drive converter must remain switched on during the cooling down phase.

Operation in the range of the thermal overload limit

Due to the high slope of the overload characteristic, the duration of a permissible overload in this range □ cannot be determined exactly. Therefore, the design of the drive converter should be assumed to have a maximum overload time of 300s.

3.3.3.2 Frequency-dependent maximum current (OL2) 400V devices

The characteristics of the maximum currents for a switching frequency which are depending on the output frequency are different for each drive converter, but the following rules are generally applicable:

- Applies for the rated switching frequency: at 0 Hz output frequency the drive converter can provide at least the rated output current.
- Lower maximum currents apply for switching frequencies > rated switching frequency.

If error (OL2) shall be triggered on exceeding the maximum currents or if the switching frequency is automatically reduced (derating) can be adjusted in the drive converter parameters.

The following characteristic curve indicates the permissible maximum current for the output frequency values 0Hz, 3Hz, 6Hz, 10Hz, 25Hz and 50Hz. If there is a deviation of the shown switching frequencies, it will be interpolated between the characteristics. Device size 19 is represented exemplary.

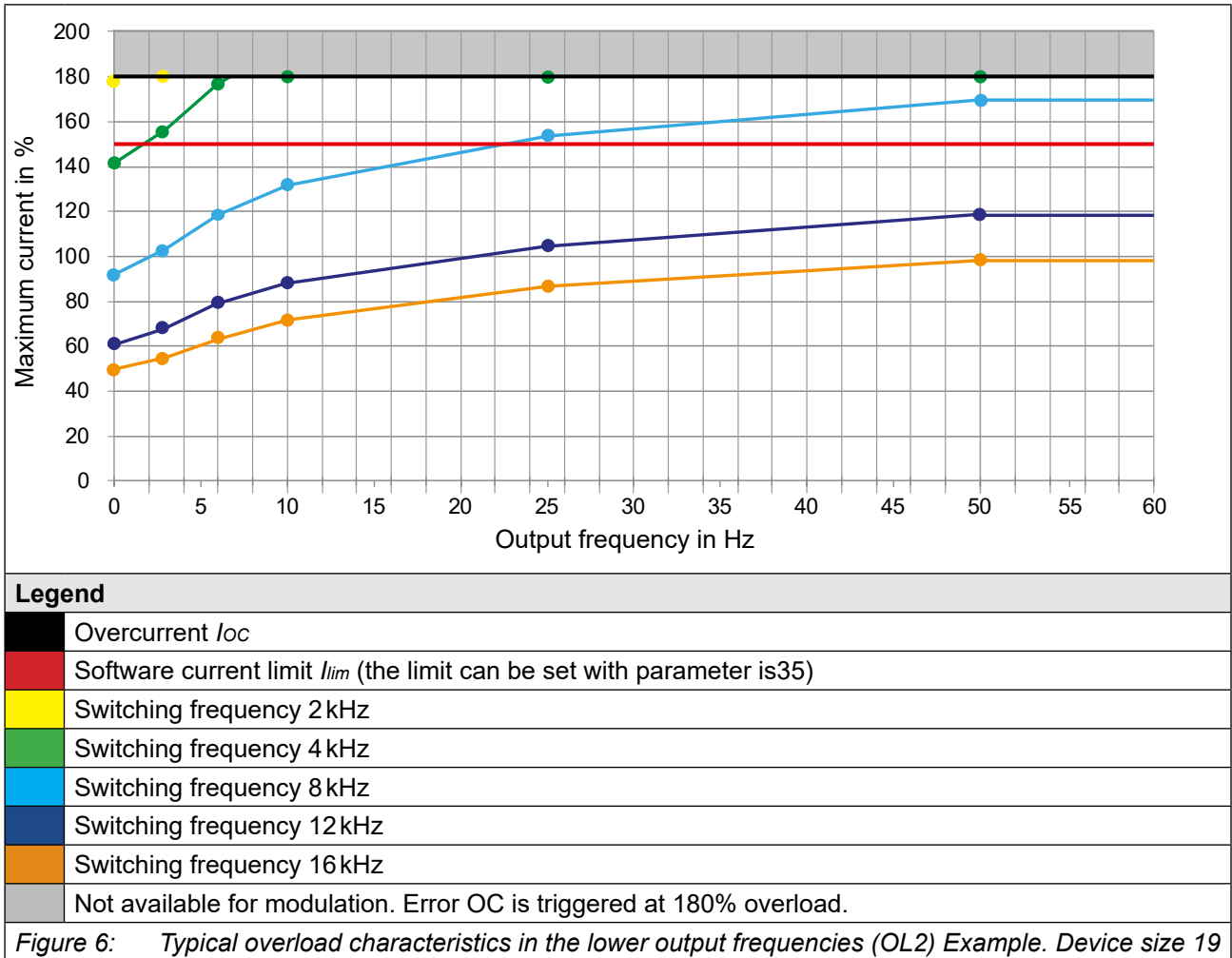

The frequency-dependent maximum current I_{lim} refers in % to the rated output current I_N .

The current remains constant from the last specified output frequency value.



The values for the respective device size are listed in the following tables.

Frequency-dependent maximum current

Device size		18					
Rated switching frequency		4 kHz					
Output frequency	f_{out} / Hz	0	3	6	10	25	50
Frequency-dependent maximum current @ f_s <i>Basic Time Period = 62.5 μs (Parameter is22=0)</i>	2 kHz	180	180	180	180	180	180
	4 kHz	162	180	180	180	180	180
	8 kHz	106	118	134	148	172	180
	16 kHz	56	64	72	78	94	104
Frequency-dependent maximum current @ f_s <i>Basic Time Period = 71.4 μs (Parameter is22=1)</i>	1.75 kHz	180	180	180	180	180	180
	3.5 kHz	175	180	180	180	180	180
	7 kHz	120	134	151	166	180	180
	14 kHz	66	75	84	92	110	121
Frequency-dependent maximum current @ f_s <i>Basic Time Period = 83.3 μs (Parameter is22=2)</i>	1.5 kHz	180	180	180	180	180	180
	3 kHz	180	180	180	180	180	180
	6 kHz	134	149	168	180	180	180
	12 kHz	76	86	96	106	126	138
Frequency-dependent maximum current @ f_s <i>Basic Time Period = 100 μs (Parameter is22=3)</i>	1.25 kHz	180	180	180	180	180	180
	2.5 kHz	180	180	180	180	180	180
	5 kHz	148	165	180	180	180	180
	10 kHz	91	102	115	127	149	163

Table 24: Frequency-dependent maximum current for device size 18

Device size		19					
Rated switching frequency		4 kHz					
Output frequency	f_{out} / Hz	0	3	6	10	25	50
Frequency-dependent maximum current @ f_s <i>Basic Time Period = 62.5 μs (Parameter is22=0)</i>	2 kHz	176	180	180	180	180	180
	4 kHz	135	150	168	180	180	180
	8 kHz	88	98	111	123	143	156
	16 kHz	46	53	60	65	78	86
Frequency-dependent maximum current @ f_s <i>Basic Time Period = 71.4 μs (Parameter is22=1)</i>	1.75 kHz	176	180	180	180	180	180
	3.5 kHz	145	161	180	180	180	180
	7 kHz	100	111	125	138	160	175
	14 kHz	55	62	70	76	91	100
Frequency-dependent maximum current @ f_s <i>Basic Time Period = 83.3 μs (Parameter is22=2)</i>	1.5 kHz	176	180	180	180	180	180
	3 kHz	155	172	180	180	180	180
	6 kHz	111	124	140	153	176	180
	12 kHz	63	72	80	88	105	115
Frequency-dependent maximum current @ f_s <i>Basic Time Period = 100 μs (Parameter is22=3)</i>	1.25 kHz	176	180	180	180	180	180
	2.5 kHz	166	180	180	180	180	180
	5 kHz	123	137	154	168	180	180
	10 kHz	75	85	95	105	124	135

Table 25: Frequency-dependent maximum current for device size 19

Device size		20					
Rated switching frequency		4 kHz					
Output frequency	f_{out} / Hz	0	3	6	10	25	50
Frequency-dependent maximum current @ f_s <i>Basic Time Period = 62.5 μs (Parameter is22=0)</i>	2 kHz	141	156	174	180	180	180
	4 kHz	108	120	134	146	168	180
	8 kHz	70	78	89	98	114	125
	16 kHz	37	42	48	52	62	69
Frequency-dependent maximum current @ f_s <i>Basic Time Period = 71.4 μs (Parameter is22=1)</i>	1.75 kHz	141	156	174	180	180	180
	3.5 kHz	116	129	144	157	180	180
	7 kHz	80	89	100	110	128	140
	14 kHz	44	50	56	61	73	80
Frequency-dependent maximum current @ f_s <i>Basic Time Period = 83.3 μs (Parameter is22=2)</i>	1.5 kHz	141	156	174	180	180	180
	3 kHz	124	138	154	168	180	180
	6 kHz	89	99	112	122	141	154
	12 kHz	50	57	64	70	84	92
Frequency-dependent maximum current @ f_s <i>Basic Time Period = 100 μs (Parameter is22=3)</i>	1.25 kHz	141	156	174	180	180	180
	2.5 kHz	133	147	164	179	180	180
	5 kHz	98	109	123	134	154	169
	10 kHz	60	68	76	84	99	108

Table 26: Frequency-dependent maximum current for device size 20

Device size		21					
Rated switching frequency		2 kHz					
Output frequency	f_{out} / Hz	0	3	6	10	25	50
Frequency-dependent maximum current @ f_s <i>Basic Time Period = 62.5 μs (Parameter is22=0)</i>	2 kHz	117	130	145	158	180	180
	4 kHz	90	100	112	122	140	153
	8 kHz	58	65	74	82	95	104
	16 kHz	31	35	40	43	52	57
Frequency-dependent maximum current @ f_s <i>Basic Time Period = 71.4 μs (Parameter is22=1)</i>	1.75 kHz	117	130	145	158	180	180
	3.5 kHz	96	107	120	131	150	163
	7 kHz	66	74	83	92	106	116
	14 kHz	36	41	46	51	61	67
Frequency-dependent maximum current @ f_s <i>Basic Time Period = 83.3 μs (Parameter is22=2)</i>	1.5 kHz	117	130	145	158	180	180
	3 kHz	103	115	128	140	160	173
	6 kHz	74	82	93	102	117	128
	12 kHz	42	47	53	58	70	76
Frequency-dependent maximum current @ f_s <i>Basic Time Period = 100 μs (Parameter is22=3)</i>	1.25 kHz	117	130	145	158	180	180
	2.5 kHz	110	122	137	149	170	180
	5 kHz	82	91	102	112	128	141
	10 kHz	50	56	63	70	82	90

Table 27: Frequency-dependent maximum current for device size 21

Device size		22					
Rated switching frequency		2 kHz					
Output frequency	f_{out} / Hz	0	3	6	10	25	50
Frequency-dependent maximum current @ f_s <i>Basic Time Period = 62.5 μs (Parameter is22=0)</i>	2 kHz	111	123	136	146	165	180
	4 kHz	82	92	104	112	127	138
	8 kHz	51	59	66	71	84	93
	16 kHz	24	28	31	35	42	47
Frequency-dependent maximum current @ f_s <i>Basic Time Period = 71.4 μs (Parameter is22=1)</i>	1.75 kHz	111	123	136	146	165	180
	3.5 kHz	90	100	112	112	127	138
	7 kHz	59	67	75	71	84	93
	14 kHz	29	34	38	35	42	47
Frequency-dependent maximum current @ f_s <i>Basic Time Period = 83.3 μs (Parameter is22=2)</i>	1.5 kHz	111	123	136	146	165	180
	3 kHz	97	108	120	129	146	159
	6 kHz	67	75	85	92	105	115
	12 kHz	34	40	44	49	58	64
Frequency-dependent maximum current @ f_s <i>Basic Time Period = 100 μs (Parameter is22=3)</i>	1.25 kHz	111	123	136	146	165	180
	2.5 kHz	104	115	128	138	155	169
	5 kHz	75	84	95	102	116	127
	10 kHz	43	49	55	60	71	79

Table 28: Frequency-dependent maximum current for device size 22

3.3.4 Power dissipation at nominal operating for 400 V devices

Device size	19	20	21	22
Power dissipation at rated operation ¹⁾ P_D / W	698	896	895	1082

Table 29: Power dissipation of the 400 V devices

¹⁾ Rated operation corresponds to $U_N = 400 V$; f_{SN} ; I_N ; $f_N = 50 Hz$ (typically value)

3.3.5 Fuse protection of the drive converters 400 V devices

Device size	Max. size of the fuse / A				
	$U_N = 400V$ gG (IEC)	$U_N = 480V$ Class „J“		$U_N = 480V$ gR	
	SCCR 30 kA	SCCR		SCCR 30 kA	Type
		5 kA	10 kA		
18	80	50	–	50	SIBA 20 189 20.50 COOPER BUSSMANN 170M1364 LITTELFUSE L70QS050
19	80	70	–	80	SIBA 20 189 20.80 EATON 170M1366
20	100	90	–	100	SIBA 20 189 20.100 EATON 170M1367
21	125	110	–	125	SIBA 20 189 20.125 EATON 170M1368
22	160	–	125	125	SIBA 20 189 20.125 EATON 170M1368

Table 30: Fusing of the 400 V / 480 V devices



Short-circuit capacity

After requests from [EN 60439-1](#) and [EN 61800-5-1](#) the following is valid for the connection to a network: The devices are suitable for use in a circuit capable of delivering not more than 30 kA eff. unaffected symmetrical short-circuit current.

3.4 General electrical data

3.4.1 Switching frequency and temperature

Device size		18	19	20	21	22
Rated switching frequency	¹⁾ f_{SN} / kHz	4			2	
Max. switching frequency	¹⁾ f_{S_max} / kHz	16				
Min. switching frequency	¹⁾ f_{S_min} / kHz	1,25				
Max. heat sink temperature	T_{HS} / °C	95	90	95		
Temperature for derating the switching frequency	T_{DR} / °C	80				
Temperature for uprating the switching frequency	T_{UR} / °C	70				
Temperature for switching to rated switching frequency	T_{EM} / °C	85				

Table 31: Switching frequency and temperature

¹⁾ The output frequency is to be limited in such a way that it does not exceed 1/10 of the switching frequency.

The drive converter cooling is designed by way that the heat sink overtemperature threshold is not exceeded at rated conditions. A switching frequency higher than the rated switching frequency also produces higher losses and thus a higher heat sink heating. If the heat sink temperature reaches a critical threshold (T_{DR}), the switching frequency can be reduced automatically step by step. This prevents that the drive converter switches off due to overheating of the heat sink. If the heat sink temperature falls below T_{UR} , the switching frequency is increased back to the setpoint. At temperature T_{EM} the switching frequency is immediately reduced to rated switching frequency. „Derating“ must be activated, for this function to work.

3.4.2 DC link / braking transistor function (GTR7)

**Activation of the braking transistor function**

In order to use the braking transistor (GTR7), the function must be activated with parameter "is30 braking transistor function".

For more information => [F6 Programming manual](#).

NOTICE

Destruction of the drive converter if the value has fallen below the minimum brake resistance value!

- The minimum brake resistance value must not fall below!

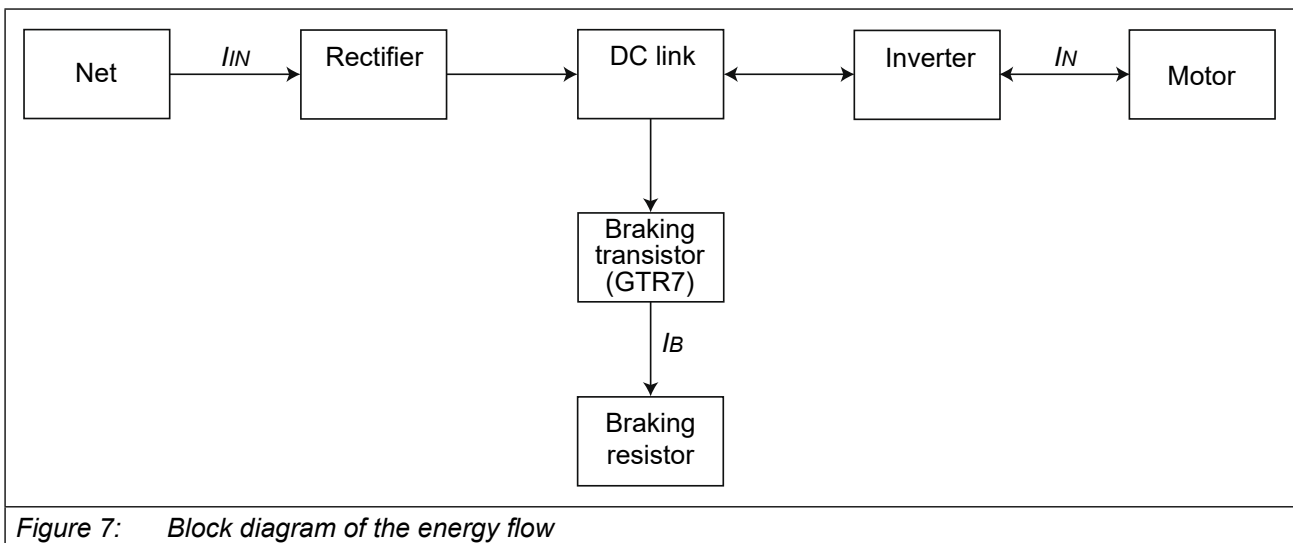

Figure 7: Block diagram of the energy flow

NOTICE

Destruction of the drive converter!

If the error "ERROR GTR7 always ON" occurs, the current consumption is switched off internally via the mains input bridge of the AC supply.

- The drive converter must be electrically isolated from the supply system within 5 minutes!

3.4.2.1 DC link / braking transistor function of the 230V devices

Device size		18
Rated DC link voltage @ $U_N = 230V$	U_{N_dc} / V	325
Rated DC link voltage @ $U_{N_UL} = 240V$	$U_{N_dc_UL} / V$	339
DC link voltage working voltage range	U_{in_dc} / V	240...373
DC switch-off level „ERROR Underpotential“	U_{UP} / V	216
DC switch-off level „ERROR Overpotential“	U_{OP} / V	400
DC switch-off level braking resistor	¹⁾ U_B / V	380
Max. braking current	I_{B_max} / A	105
Braking transistor (GTR7)	²⁾	Max. cycle time: 120s; ED: 50%
Min. braking resistor value	R_{B_min} / Ω	4
Protection function for braking transistor (GTR7)		Short-circuit monitoring
Protective function braking resistor (Error GTR7 always on)	³⁾	Feedback signal evaluation and current shutdown
DC link capacity	$C / \mu F$	6800

Table 32: DC link / braking transistor function of the 230V devices

¹⁾ The DC switching level for the braking transistor is adjustable. The default value is the value specified in the table.

²⁾ The cyclic duration factor is additionally limited by the used braking resistor.

³⁾ The feedback signal evaluation monitors the functionality of the braking transistor (GTR7). Power off occurs via the internal mains input bridge of the AC supply.

3.4.2.2 DC link / braking transistor function of the 400V devices

Device size		18	19	20	21	22
Rated DC link voltage @ $U_N = 400V$	U_{N_dc} / V	565				
Rated DC link voltage @ $U_{N_UL} = 480V$	$U_{N_dc_UL} / V$	680				
DC link voltage working voltage range	U_{in_dc} / V	390...780				
DC switch-off level „ERROR Underpotential“	U_{UP} / V	240				
DC switch-off level „ERROR Overpotential“	U_{OP} / V	840				
DC switch-off level braking resistor	¹⁾ U_B / V	780				
Max. braking current	I_{B_max} / A	93				105
Braking transistor (GTR7)	²⁾	Max. cycle time: 120 s; ED: 50 %				
Min. braking resistor value	R_{B_min} / Ω	9				8
Protective function braking resistor (Error GTR7 always on)	³⁾	Feedback signal evaluation and current shutdown				
Protection function for braking transistor (GTR7)		Short-circuit monitoring				
DC link capacity	$C / \mu F$	2380	2380	2720	3400	4080

Table 33: DC link / braking transistor function of the 400V devices

- ¹⁾ The DC switching level for the braking transistor is adjustable. The default value is the value specified in the table.
- ²⁾ The cyclic duration factor is additionally limited by the used braking resistor.
- ³⁾ The feedback signal evaluation monitors the functionality of the braking transistor (GTR7). Power off occurs via the internal mains input bridge of the AC supply.

3.4.3 Fan

Device size		18	19	20	21	22
Interior fan	Number	1				
	Speed-variable	yes				
Heat sink fan	Number	2				
	Speed-variable	yes				

Table 34: Fan



The fans are speed adjustable! Depending on the setting of the software they are automatically controlled to high or low speed.

NOTICE

Destruction of the fan!

- ▶ Take care that no foreign substances drop into the fan!

3.4.3.1 Switching behaviour of the fans

The fans have different switch-on and switch-off points. The switching point for the switch-on temperature \square and the maximum speed level \square of the fans are adjustable. The switching point for the switch-off temperature \square cannot be changed.

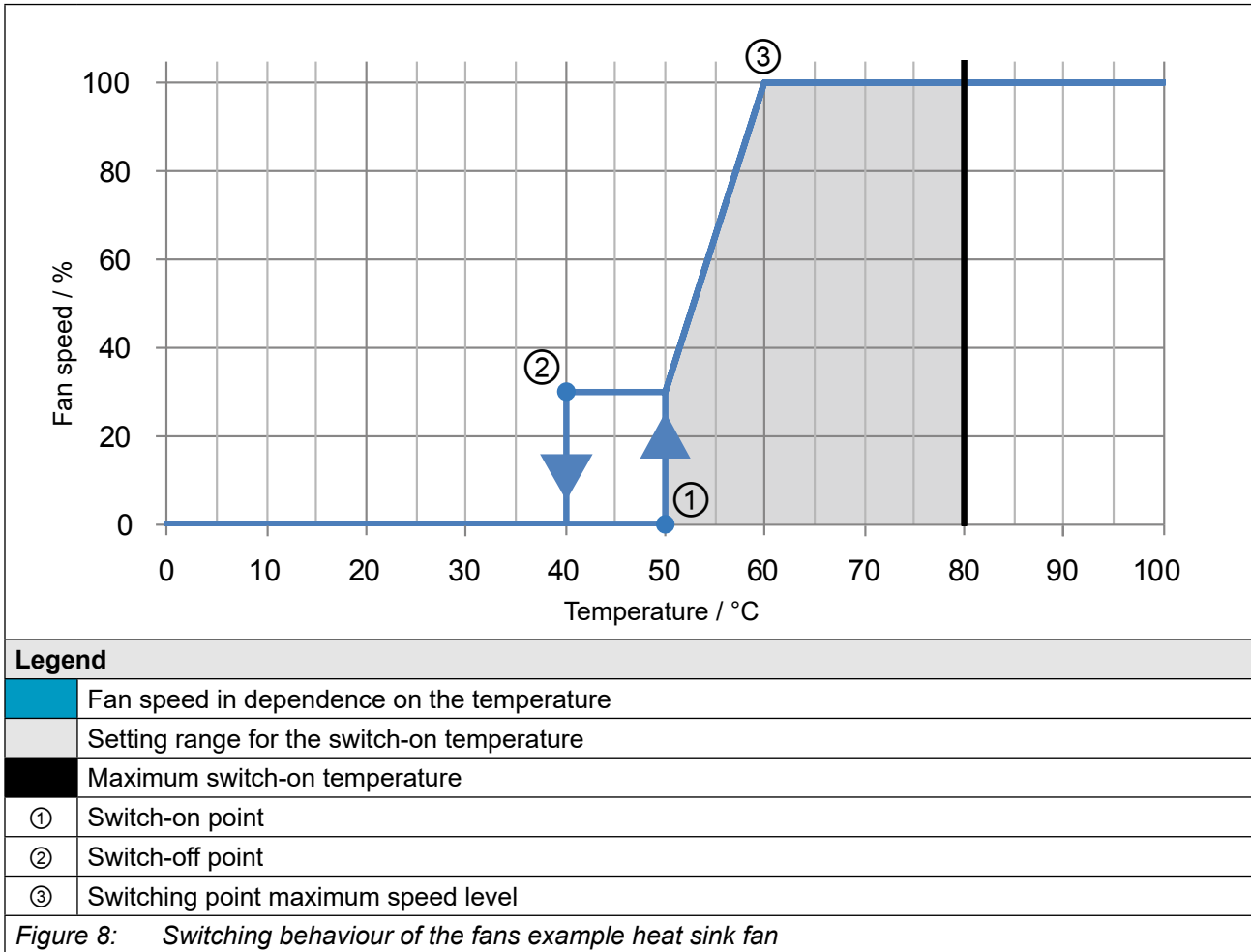

3.4.3.2 Switching points of the fans

The switching point for the switch-on temperature and the maximum speed level of the fans are adjustable. The following table shows the default values.

Fan		Heat sink	Interior
Switch-on temperature	$t / ^\circ\text{C}$	50	45
Maximum speed level	$t / ^\circ\text{C}$	60	55

Table 35: Switching points of the fans

3.4.3.3 Airflow of the drive converter

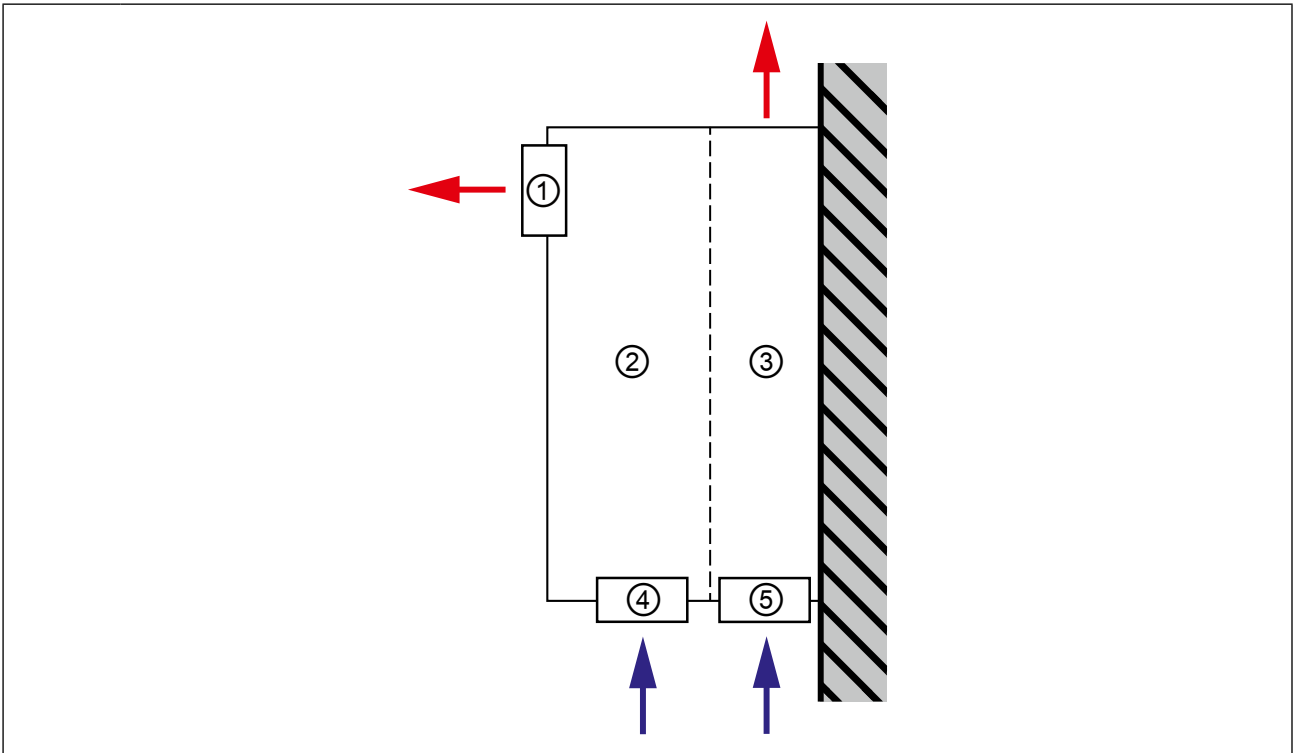

Legend	
	Airflow direction
①	Interior fan (from housing 4)
②	Drive converter (power unnit and control)
③	Drive converter (heat sink)
④	Interior fan for (housing 2 and 3)
⑤	Heatsink fan

Figure 9: Airflow of the drive converter

3.5 Dimensions and weights

3.5.1 Built-in version air cooler

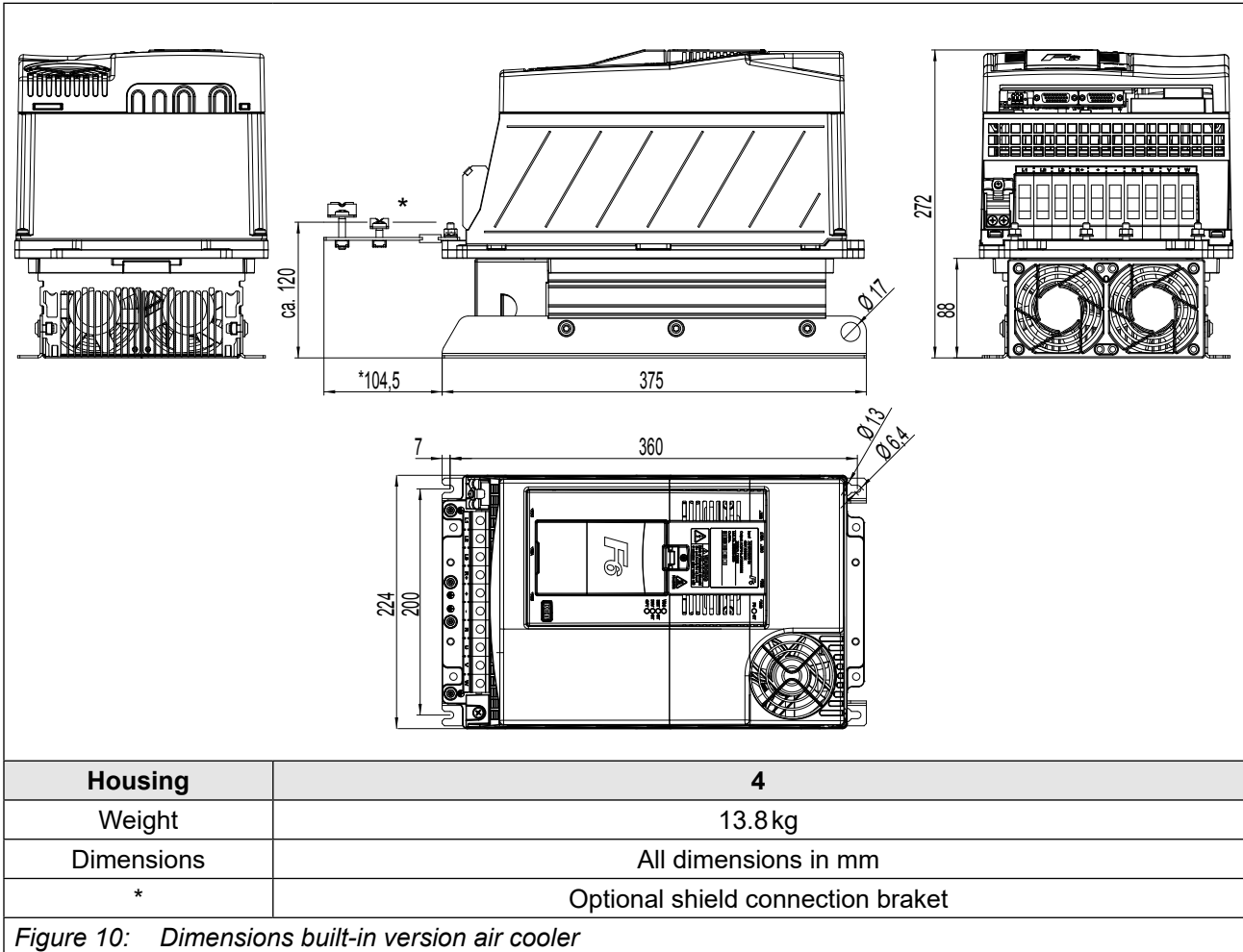

3.5.2 Built-in version fluid cooler (water)

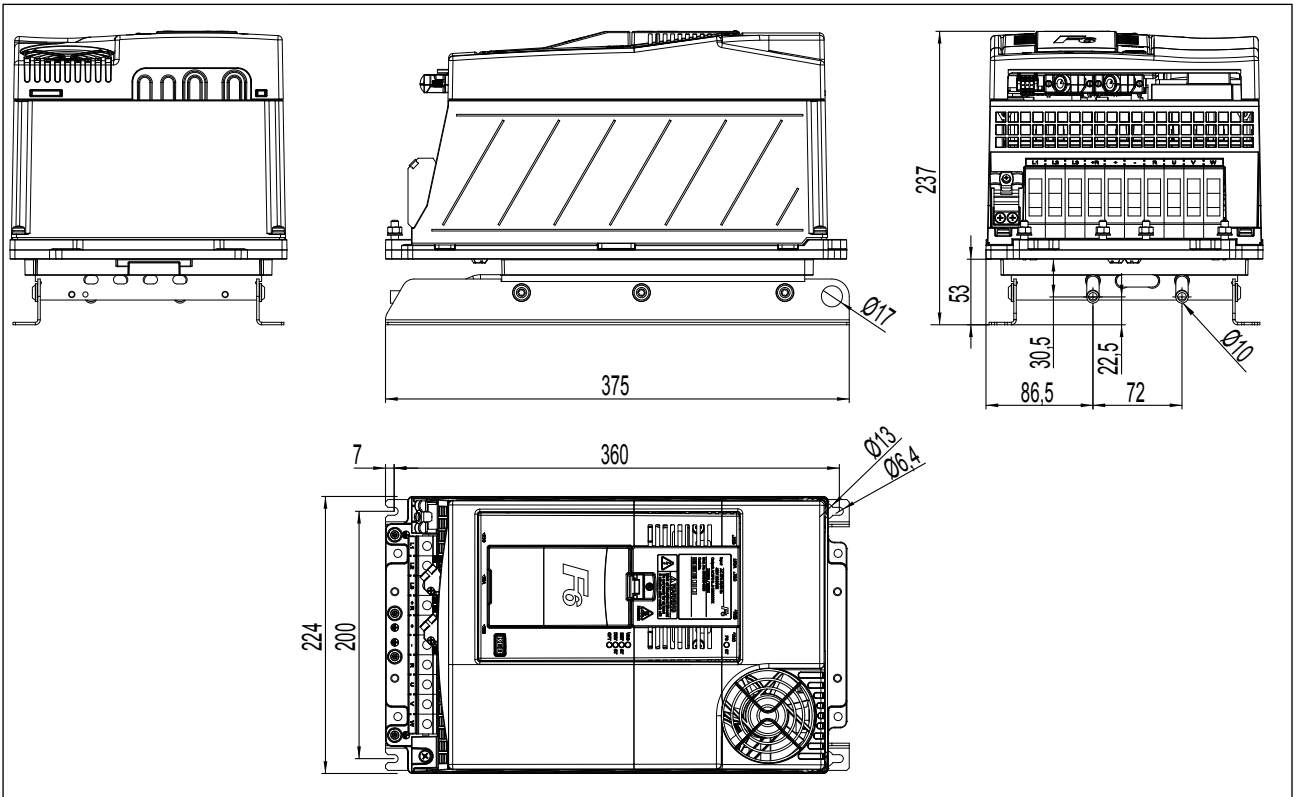

Housing	4
Weight	12.2 kg
Dimensions	All dimensions in mm

Figure 11: Dimensions built-in version fluid cooler (water)

3.5.3 Push-through version air cooler IP20, IP54-ready

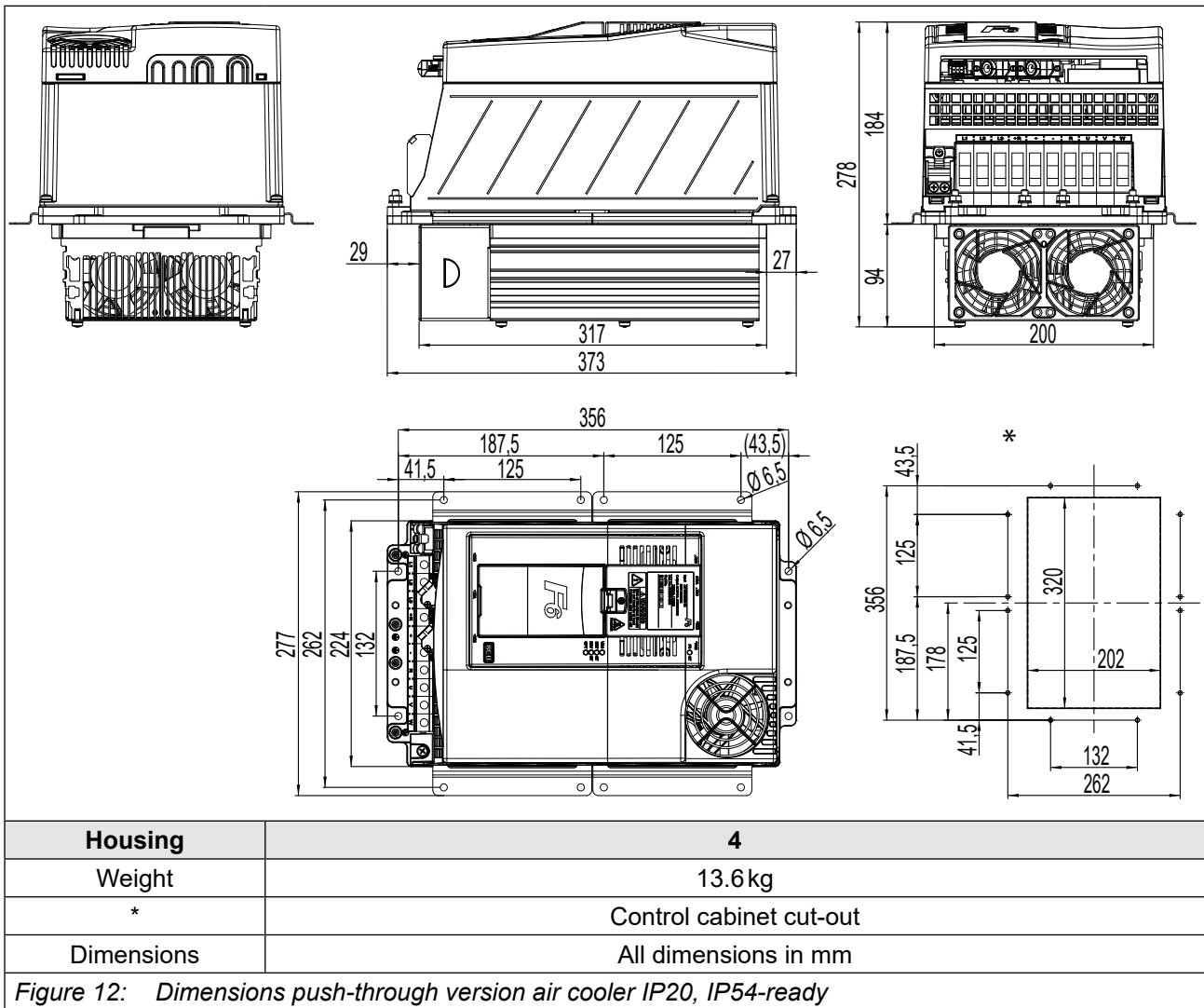

IP54 zone: Heat sink underneath the mounting plate

For proper installation, the enclosed seal (40F6T45-0002) must be installed between heat sink and housing (e.g. cabinet wall). The tightness must be checked after the installation. If properly installed, the separation to the housing corresponds to degree of protection IP54. However, the fans must be protected against unfavorable environmental influences. These include combustible, oily or dangerous fumes or gases, corrosive chemicals, coarse foreign bodies and excessive dust. This applies especially to the access of the heatsink from the top (air outlet). Icing is inadmissible.

IP20 zone: Device above the mounting plate

Power connections excluded => „*Klimatische Umweltbedingungen*“. This part is intended for the installation in a suitable housing for the required degree of protection (e.g. control cabinet).

UL: Device heat sink is classified as NEMA type 1.

3.5.4 Push-through version fluid cooler (water) IP20, IP54-ready

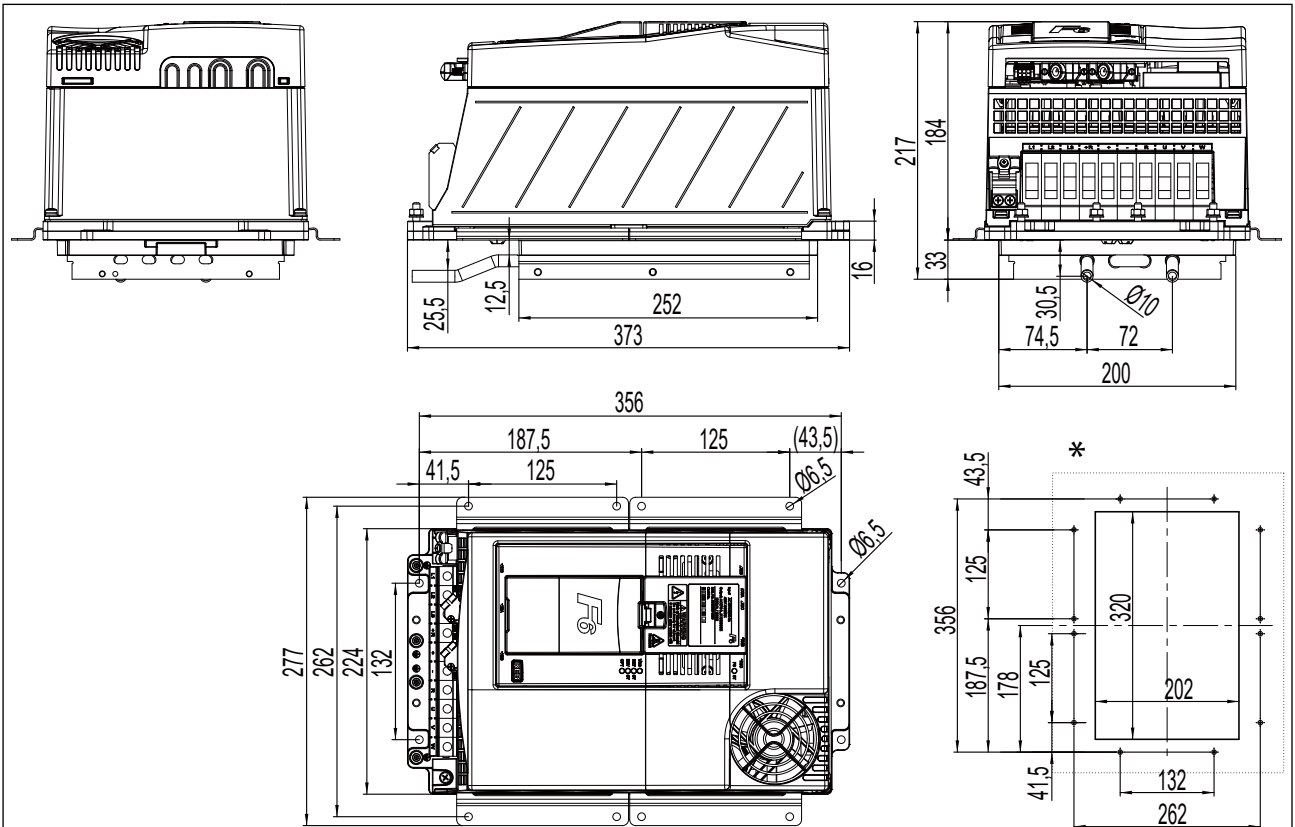

Housing	4
Weight	12 kg
*	Control cabinet cut-out
Dimensions	All dimensions in mm

Figure 13: Dimensions push-through version fluid cooler (water) IP20, IP54-ready



IP54 zone: Heat sink underneath the mounting plate

For proper installation, the enclosed seal (40F6T45-0002) must be installed between heat sink and housing (e.g. cabinet wall). The tightness must be checked after the installation. If properly installed, the separation to the housing corresponds to degree of protection IP54.

IP20 zone: Device above the mounting plate

Power connections excluded => „*Klimatische Umweltbedingungen*“. This part is intended for the installation in a suitable housing for the required degree of protection (e.g. control cabinet).

UL: Device heat sink is classified as NEMA type 1.

3.5.5 Push-through version fluid cooler (oil) IP54-ready

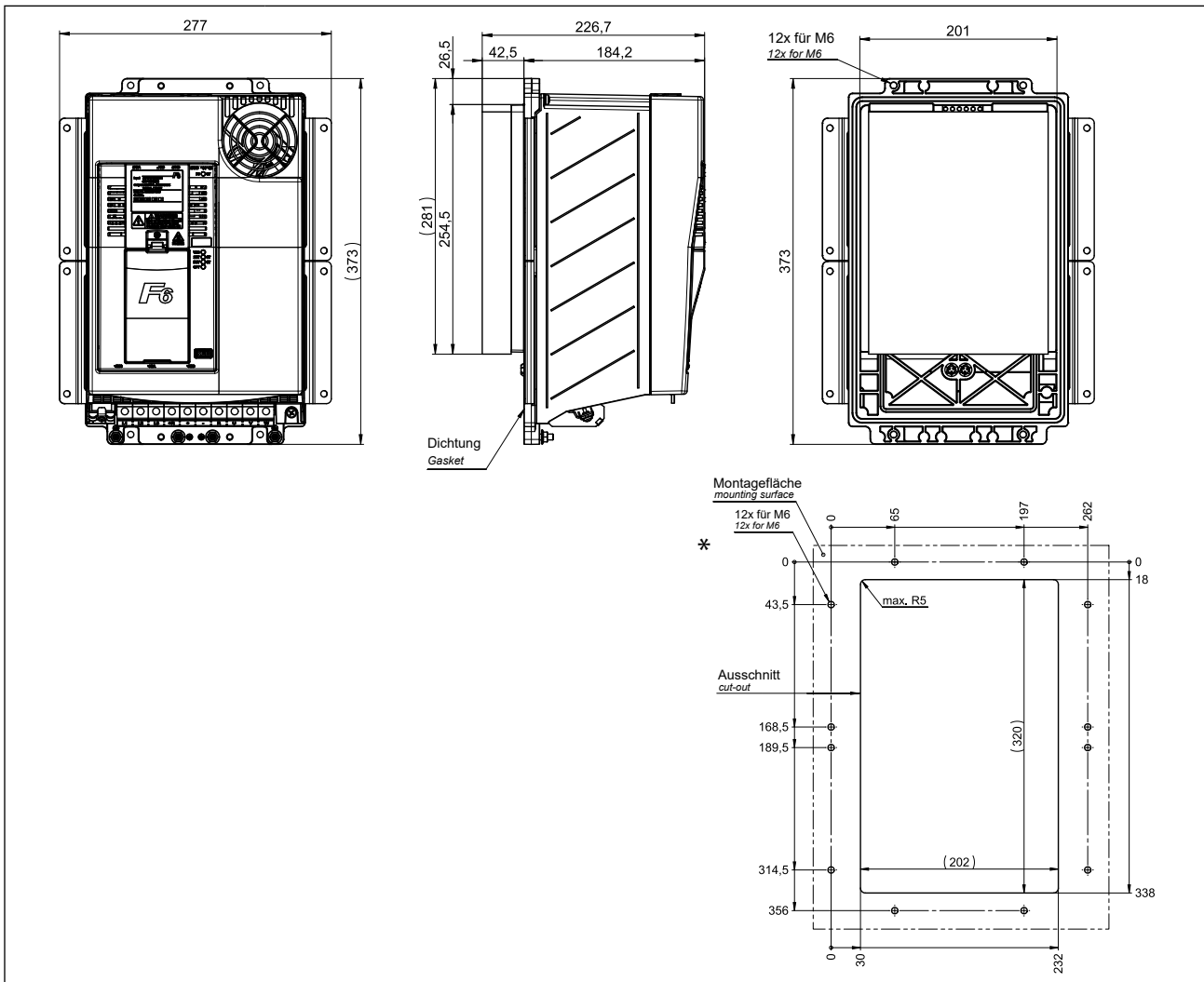

Housing	4
Weight	11.5kg
*	Control cabinet cut-out
Dimensions	All dimensions in mm

Figure 14: Dimensions push-through version fluid cooler (oil) IP54-ready



IP54 zone: Heat sink underneath the mounting plate

For proper installation, the enclosed seal (40F6T45-0002) must be installed between heat sink and housing (e.g. cabinet wall). The tightness must be checked after the installation. If properly installed, the separation to the housing corresponds to degree of protection IP54.

IP20 zone: Device above the mounting plate

Power connections excluded => „*Klimatische Umweltbedingungen*“. This part is intended for the installation in a suitable housing for the required degree of protection (e.g. control cabinet).

UL: Device heat sink is classified as NEMA type 1.

3.5.6 Control cabinet installation

3.5.6.1 Mounting instructions

For the mounting of the drive converters the following mounting materials with the appropriate quality were tested by KEB.

Required material	Tightening torque
Hexagon-head screw <i>ISO 4017</i> - M6 - 8.8	9Nm 79lb inch
Flat washer <i>ISO 7090</i> - 6 - 200 HV	–
<i>Table 36: Mounting instructions for built-in version</i>	

Required material	Tightening torque
Hexagon-head screw <i>ISO 4017</i> - M6 - 8.8	9Nm 79lb inch
Flat washer <i>ISO 7090</i> - 6 - 200 HV	–
<i>Table 37: Mounting instructions for push-through version</i>	

NOTICE

Use of other fixing material

- ▶ The alternatively selected fixing material must meet the above material characteristics (quality) and tightening torques!

The use of other fixing materials is beyond the control of KEB and is therefore the sole responsibility of the customer.

3.5.6.2 Mounting distances

Power dissipation for the control cabinet dimension => „*Verlustleistung bei Bemessungsbetrieb 400 V-Geräte*“. A lower value can be used here depending on the operating mode/load.



Mounting the drive converter

For reliable operation, the drive converter must be mounted without any distance on a smooth, closed, metallicly bright mounting plate.

Mounting distances	Dimension	Distance in mm	Distance in inch
	A	150	6
	B	100	4
	C	30	1.2
	D	0	0
	E	0	0
	F ¹⁾	50	2
	1) Distance to preceding elements in the control cabinet door.		

Figure 15: Mounting distances

If construction-conditioned the control cabinet cannot be without indoor ventilation, appropriate filters must avoid suction of foreign objects.

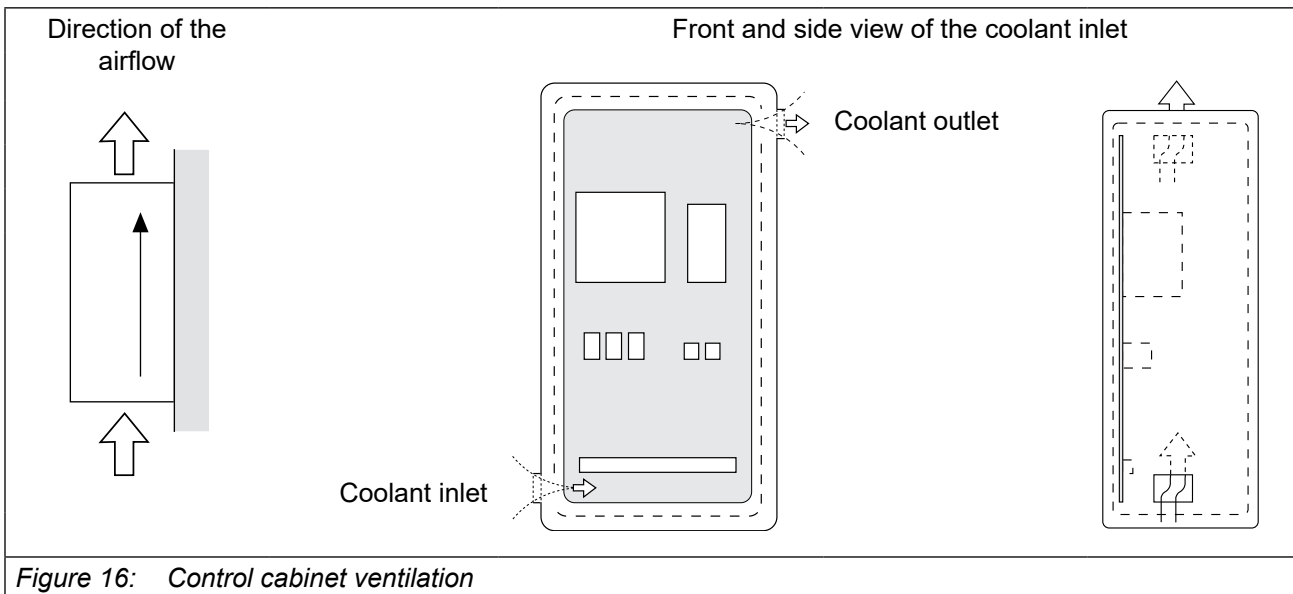

Figure 16: Control cabinet ventilation

4 Installation and Connection

4.1 Overview of the COMBIVERT F6

Housing 4		No.	Name	Description
		1	–	Shield clamps for shielded control cables.
		2	–	Fixing points for optional shield connection bracket. The shielding, e.g. of the motor cable, is placed on the base plate in the control cabinet or on the optionally available shield connection bracket 00F6V80-4001.
		3	–	LEDs (see the manual for control unit chapter „Overview“) • For control board COMPACT: FS without function. • For control card APPLICATION and PRO: Status indication of the safety module
		4	–	Interior fan
		5	PE	Protective earth; at connection to protective earth each terminal may be assigned only once.
		6	X1A	Power circuit terminals for: • Mains input • Braking resistor • DC supply • Motor connection
<p>Figure 17: F6 housing 4 top view</p>				

Housing 4		No.	Name	Description			
	1	–	Shield clamps for shielded control cables.				
	5	PE	Protective earth; at connection to protective earth each terminal may be assigned only once.				
	6	X1A	Power circuit terminals for: <ul style="list-style-type: none"> • Mains input • Braking resistor • DC supply • Motor connection 				
	7	X1C	Terminal for: <ul style="list-style-type: none"> • Motor temperature monitoring • Brake control 				
	8	X3A	Encoder interface channel A				
	9	X3B	Encoder interface channel B				
	10	–	Heat sink fan				
	1	5	10	5	5	10	5
	<p>Figure 18: F6 housing 4 front view</p>						

Housing 4		No.	Name	Description
	4	–	Interior fan	
	11	X4C	Fieldbus interface (out)	
	12	X4B	Fieldbus interface (in)	
	13	X2C	Control terminal block for <ul style="list-style-type: none"> • CAN bus • Analog inputs and analog output 	
	14	X2B	Safety functions / 24 V DC voltage supply / 2 digital outputs	
	15	X2A	Control terminal block for digital inputs and outputs.	
	16	–	Shield clamps for shielded control cables.	

Figure 19: F6 housing 4 rear view with control board COMPACT



Further information can be found in the respective control board manual.



Instructions for use COMBIVERT F6 control board COMPACT
www.keb.de/fileadmin/media/Manuals/dr/ma_dr_f6-cu-k-inst-20144795_en.pdf



Instructions for use COMBIVERT F6 control board APPLICATION
www.keb.de/fileadmin/media/Manuals/dr/ma_dr_f6-cu-a-inst-20118593_en.pdf



Instructions for use COMBIVERT F6 control board PRO
www.keb.de/fileadmin/media/Manuals/dr/ma_dr_f6-cu-p-inst-20182705_en.pdf



4.2 Connection of the power unit

NOTICE

Destruction of the drive converter!

- ▶ Never exchange mains input and motor output!

4.2.1 Connection of the voltage supply

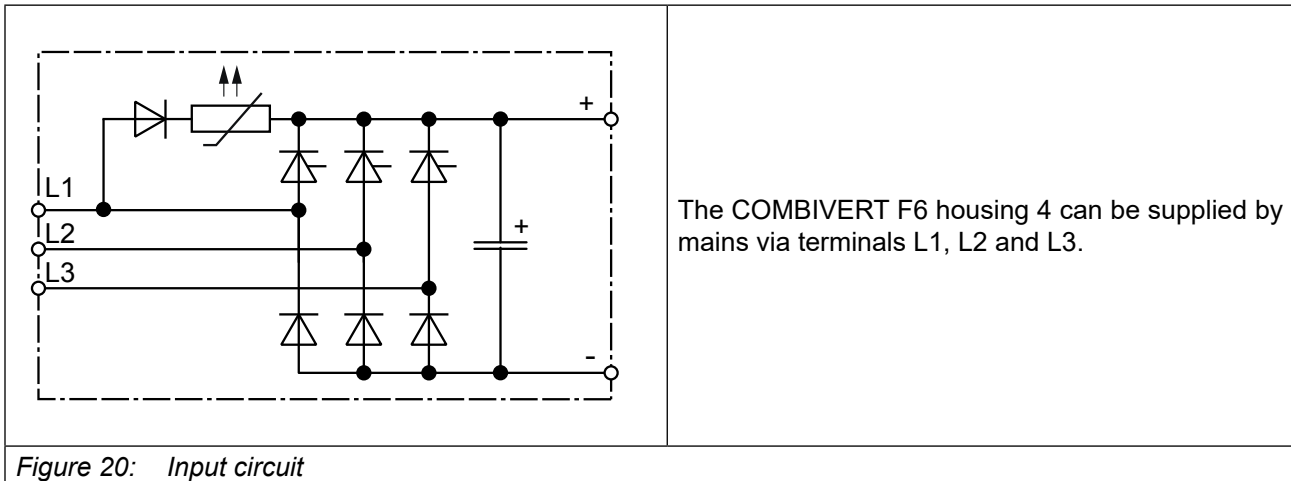

The COMBIVERT F6 housing 4 can be supplied by mains via terminals L1, L2 and L3.

Figure 20: Input circuit



Minimum waiting period between two switch-on procedures 5 minutes!

Cyclic switching on and off of the device leads to temporary high resistance of the resistor (PTC) in the input. After the PTC has cooled down, it can be restarted without restrictions.

4.2.1.1 Terminal block X1A

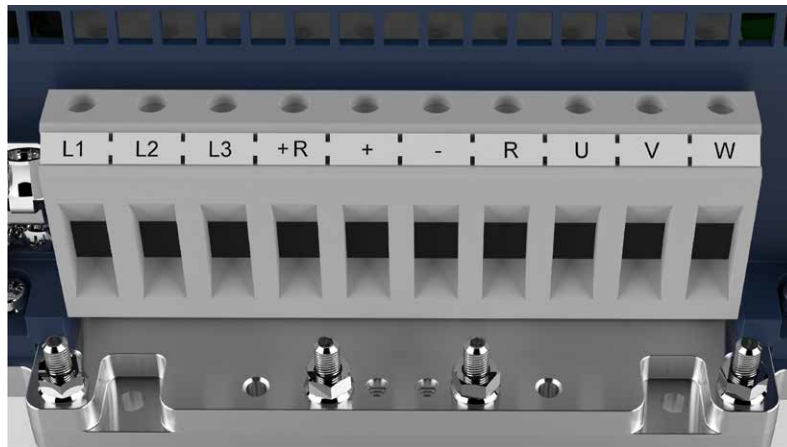

Name	Function	Cross-section for terminal connection	Tightening torque	Max. number of conductors
L1	Mains connection 3-phase	Flexible cable with wire-end ferrule 1.5...35 mm ² (without wire-end ferrule up to max. 50 mm ²) With 2 cables max. 16 mm ²	3.2...3.7 Nm 28...32 lb inch	For IEC: 2 For UL: 1
L2				
L3				
+R	Connection for braking resistor (between +R and R)	UL: Flexible cable without wire-end ferrule AWG 16...1	3.2...3.7 Nm 28...32 lb inch	For IEC: 2 For UL: 1
+	DC terminals			
-				
R	Connection for braking resistor (between +R and R)	UL: Flexible cable without wire-end ferrule AWG 16...1	3.2...3.7 Nm 28...32 lb inch	For IEC: 2 For UL: 1
U	Motor connection			
V				
W				

Figure 21: Terminal block X1A

4.2.2 Protective earth and functional earth



Protective and functional earth must not be connected to the same terminal.

4.2.2.1 Protective earth

The protective earth (PE) serves for electrical safety particularly personal protection in error case.



Electric shock due to incorrect dimensioning!



► Cross-section wire to ground should be selected according to *DIN IEC 60364-5-54!*

Name	Function	Connection type	Tightening torque
PE,	Connection for protective earth	M6 threaded pin with nut for 6.5 mm crimp connectors	6.1...12 Nm 54...106 lb inch

Figure 22: Connection for protective earth



Incorrect installation of the PE connection

Only M6 threaded pins with nut may be used as connection for protective earth!

4.2.2.2 Functional earthing

A functional earthing may also be necessary, if for EMC requirements additional potential equalization between devices or parts of the system must be available.



The use of the functional earth (FE) is not required if the frequency inverter is EMC-technically wired.

The functional earth may not be wired green/ yellow!



Notes on EMC-compatible installation can be found here.
www.keb.de/fileadmin/media/Manuals/emv/0000neb0000.pdf



4.2.3 AC mains connection

4.2.3.1 AC supply 3-phase

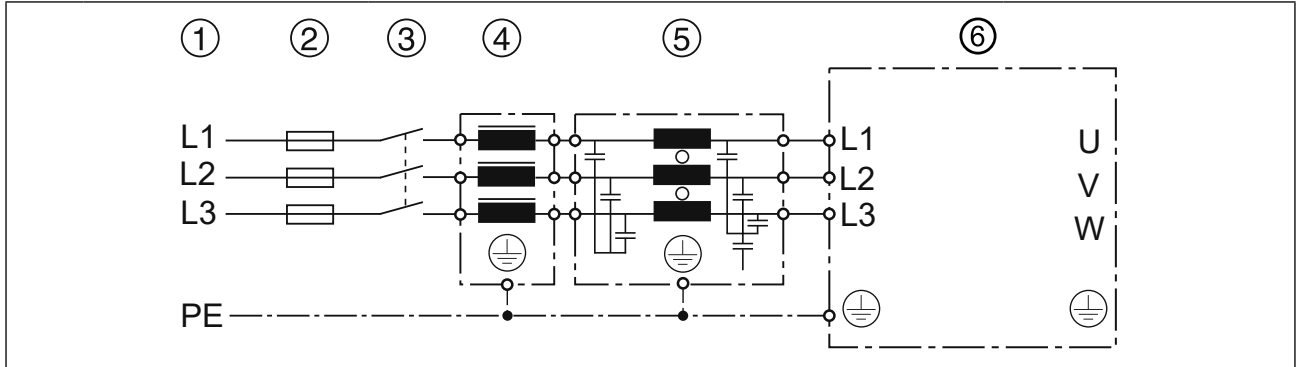

No.	Type	Description
①	Mains phase	3-phase
	Mains form	TN, TT
		IT
Personal protection	RCMA with separator or RCD type B	Insulation monitors
②	Mains fuses	Type gG or MCCB
③	Mains contactor	
④	Mains choke	see notes under the table
⑤	HF filter for TN-, TT systems	Required for compliance with the limit values in accordance with EN 61800-3 .
	HF filter for IT systems	
⑥	KEB COMBIVERT	F6

Figure 23: Connection of the mains supply 3-phase

4.2.3.2 Mains supply line

The conductor cross-section of the mains supply line is determined by the following factors:

- Input current of the drive converter
- Used line type
- Installation and ambient temperatures
- The locally valid electrical regulations



The project engineer is responsible for the design.

4.2.3.3 Note on hard power systems

The service life of drive converters with voltage DC link depends on the DC voltage, surrounding temperature and the current load of the electrolytic capacitors in the DC link. The use of mains chokes can increase the service life of the condensators to a considerable extent, especially when connecting to „hard“ power systems or when under permanent drive load (continuous duty).

The term "hard" power system means that the nodal point power (S_{Net}) of the mains is very high ($\gg 200$) compared to the rated apparent output power of the drive converter (S_{out}).

$k = \frac{S_{Net}}{S_{out}} \gg 200$	e.g.	$k = \frac{2 \text{ MVA (supply transformer)}}{62 \text{ kVA (21F6)}} = 33 \rightarrow$	no choke required
---------------------------------------	------	---	----------------------



A listing of filters and chokes => „[Filters and chokes](#)“

4.2.4 DC connection

4.2.4.1 Terminal block X1A DC connection

NOTICE

DC operation is only permitted after consultation with KEB!

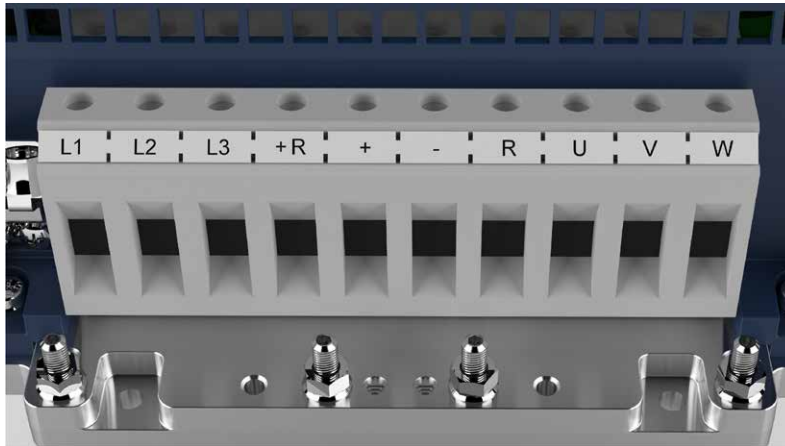

Name	Function	Cross-section for terminal connection	Tightening torque	Max. number of conductors
+	DC terminals	Flexible cable with wire-end ferrule 1.5...35 mm ² (without wire-end ferrule up to max. 50 mm ²) With 2 cables max. 16 mm ²	3.2...3.7 Nm 28...32 lb inch	For IEC: 2 For UL: 1
-				

Figure 24: Terminal block X1A DC connection

4.2.5 Connection of the motor

4.2.5.1 Wiring of the motor

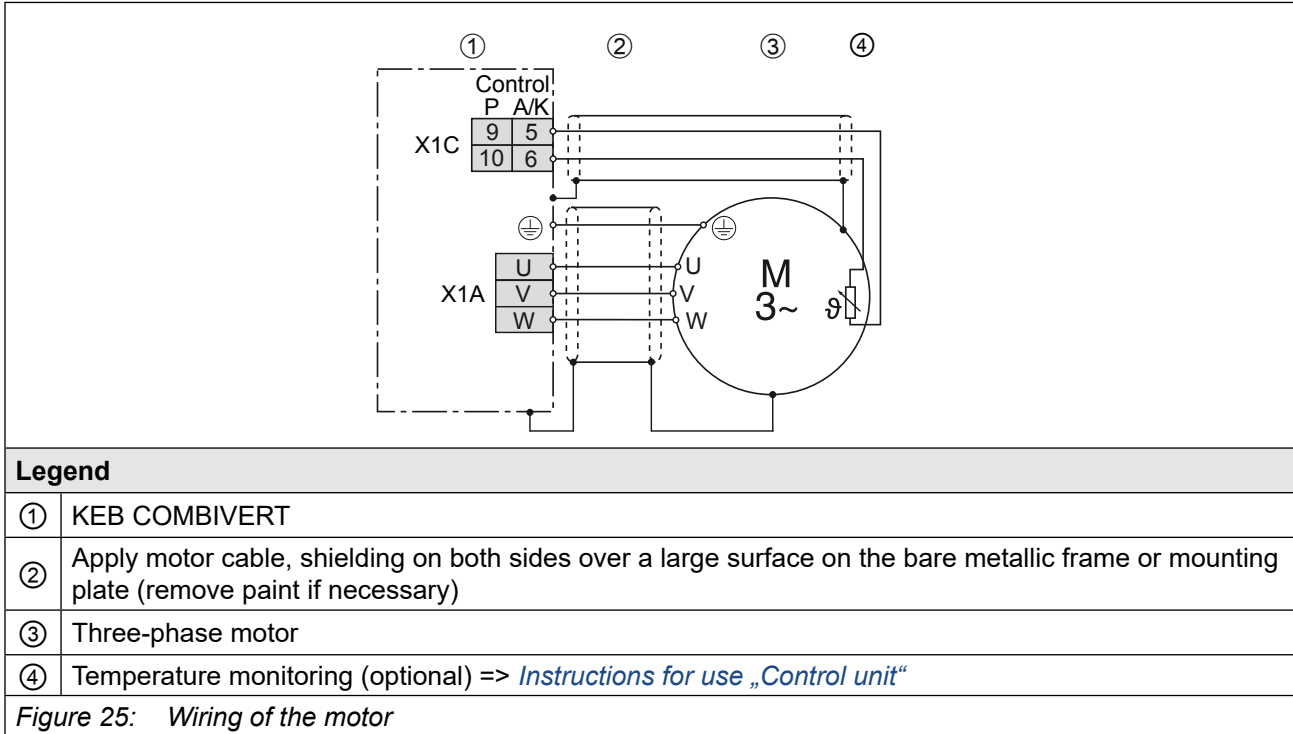

4.2.5.2 Terminal block X1A motor connection

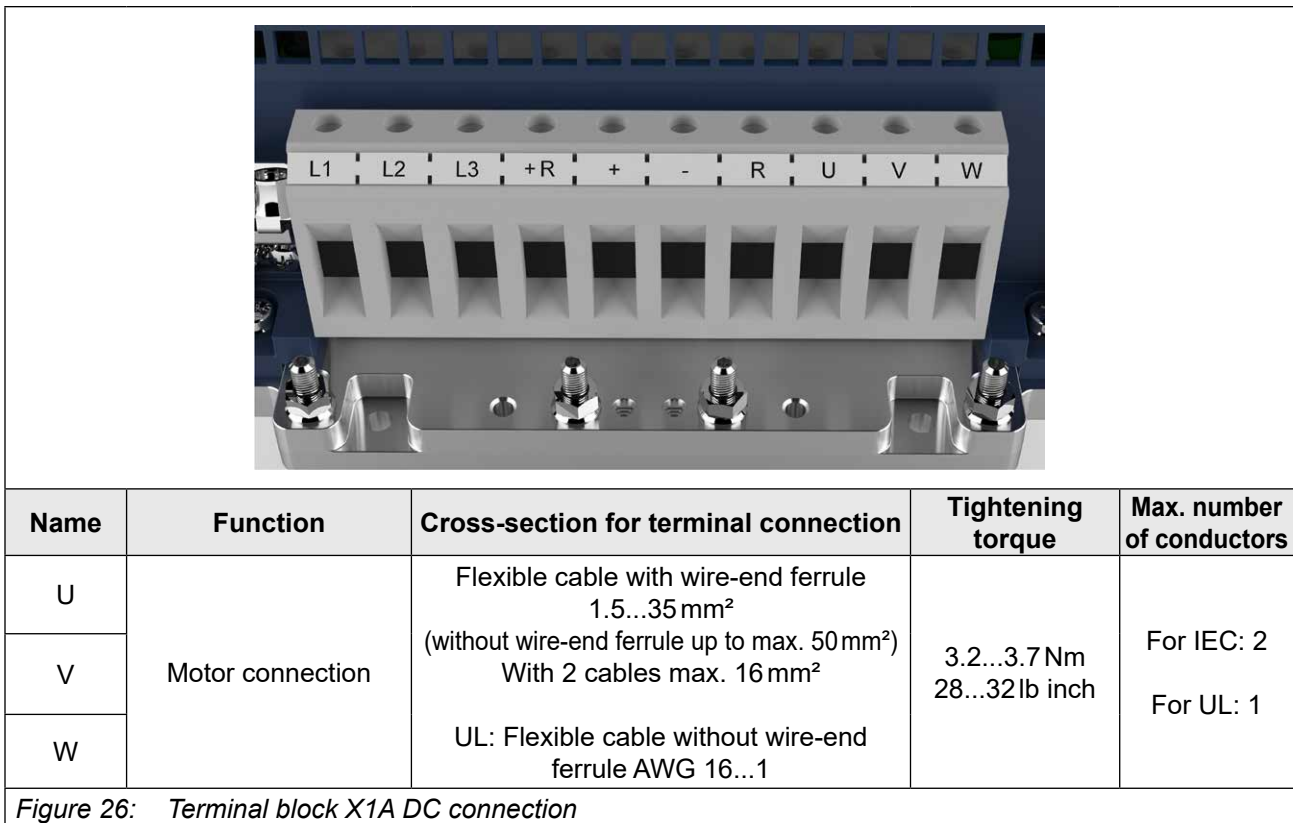

4.2.5.4 Selection of the motor line

The correct cabling as well as the motor line itself play an important part in case of low power in connection with long motor line lengths. Low-capacitance line (phase/phase < 65 pF/m, phase/screen < 120 pF/m) at the inverter output have the following effects:

- allow major motor line lengths („Selection of the motor line“)
- better EMC properties (reduction of the common-mode output currents to earth)

The use of shielded motor lines with symmetrical structure is required for higher motor power (from 30 kW). In these lines the protective earth conductor is tripartite and evenly arranged between the phase lines. A cable without protective earth conductor can be used if local regulations so permit. Then the protective earth conductor must be laid externally. Certain lines also permit the shield for the use as protective earth conductor. For this, observe the details of the line manufacturer!

Figure 27: Symmetrical motor line

4.2.5.3 Motor cable length and conducted interferences at AC supply

The maximum motor cable length is depending on the capacity of the motor cable as well as on the EMC emitted interference. External measures must be taken here (e.g. the use of a line filter). The following information is valid for the operation under rated conditions and the use of KEB listed filters under chapter => „Filters and chokes“!

Device size	Max. motor cable length shielded		max. leakage current (at $f_N \leq 100$ Hz)
	in accordance with EN 61800-3		
	Category C2		
	Motor cable (low capacitance)		
18	50m		< 5mA
19			
20			
21			
22			

Table 38: Max. motor cable length



The line length can be increased significant by using motor chokes or motor filters. KEB recommends the use of motor chokes or filters for a cable length upto 25m.

4.2.5.5 Motor cable length for parallel operation of motors

The resulting motor cable length for parallel operation of motors, or parallel installation with multiple cables arises from the following formula:

$$\text{resulting motor cable length} = \sum \text{single cable lengths} \times \sqrt{\text{Number of motor cables}}$$

4.2.5.6 Motor cable cross-section

The motor cable cross-section is dependent

- on the characteristic of the output current (e.g. harmonic content).
- on the real effective value of the motor current.
- on the cable length.
- on the type of the used line.
- on the ambient conditions such as bundling and temperature.

4.2.5.7 Interconnection of the motor

NOTICE

Incorrect behavior of the motor!

- ▶ The connecting-up instructions of the motor manufacturer are always generally valid!

Protect motor against voltage peaks !

- ▶ Drive converters switch at the output with high dv/dt. Voltage peaks that endanger the insulation system at the motor can occur especially in case of long motor cables (>15 m). A motor choke, a dv/dt-filter or sine-wave filter can be used to protect the motor with regard to the operating mode.

4.2.5.8 Connection of the temperature monitoring and brake control (X1C)

A switchable temperature evaluation is implemented in the COMBIVERT.

There are different types for the evaluation available. These are depending on the control board => *instruction manual „control board“*.

The desired operating mode can be adjusted via software (dr33). If the evaluation is not required, it must be deactivated via software (parameter pn33 = 7) => *Programming manual*

X1C	PIN	Name	Description
	1	BR+	Brake control / output +
	2	BR-	Brake control / output -
	3	reserved	–
	4	reserved	–
	5	TA1	Temperature detection / output +
	6	TA2	Temperature detection / output -

Figure 28: Terminal block X1C for control board APPLICATION and COMPACT

X1C	PIN	Name	Description
	1	BR+	Brake control / output +
	2	BR-	Brake control / output -
	3	0V	For supply of the checkback inputs
	4	24Vout	
	5	DIBR1	Checkback input 1 for brake and relay
	6	DIBR2	Checkback input 2 for brake and relay
	7	reserved	–
	8	reserved	–
	9	TA1	Temperature detection / output +
		DSL+	Digital motor temperature and position detection
10	TA2	Temperature detection / output -	
	DSL-	Digital motor temperature and position detection	

Figure 29: Terminal block X1C for control board PRO

NOTICE

Malfunctions due to incorrect line or laying!

Malfunctions of the control due to capacitive or inductive coupling.

- ▶ Do not route cables from the motor temperature sensor (also shielded) together with control cables.
- ▶ Cables from the motor temperature sensor within the motor cables may only be used with double shielding!
- ▶ The input of the temperature detection has basic isolation.

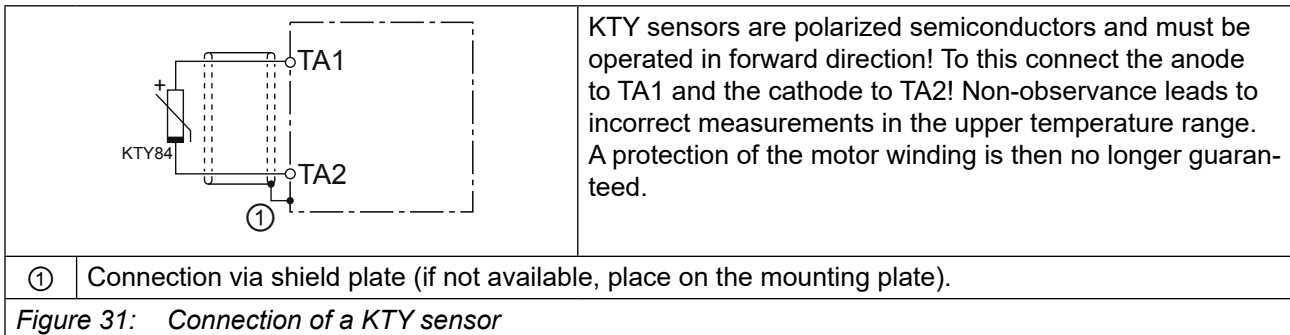
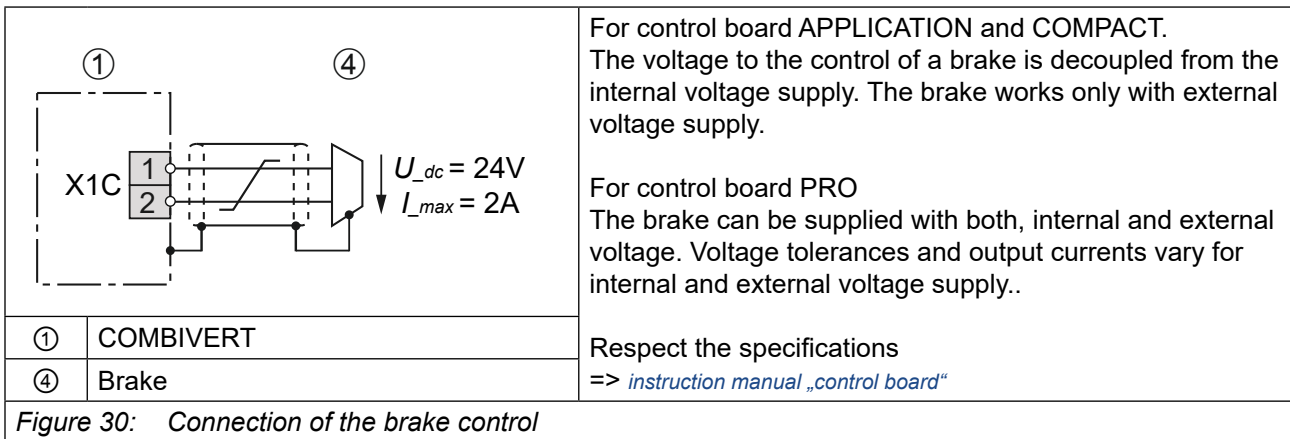

NOTICE

No protection of the motor winding in case of wrong connection.

- ▶ Operate KTY sensors in forward direction.
- ▶ KTY sensors may not be combined with other detections.

NOTE

„Basic insulation“ against SELV voltage of the control. A system voltage (Phase – PE) of 300 V is defined. Consequently, the connected sensors also must have a „basic insulation“ to the mains potential (e.g. motor winding)!



More information about the wiring of the temperature monitoring and the brake control are described in the respective control unit manual.

4.2.6 Connection and use of a braking resistor

⚠ CAUTION**Fire risk by using brake resistors !**

- ▶ The risk of fire can be significantly reduced by using „intrinsically safe braking resistors“ or by using suitable monitoring functions / circuits.

NOTICE**Destruction of the frequency inverter if the value has fallen below the minimum brake resistance value!**

- ▶ The minimum brake resistance value must not fall below!
„Device data of the 400V devices“

⚠ CAUTION**Hot surfaces caused by load of the braking resistor!****Burning of the skin!**

- ▶ Cover hot surfaces safe-to-touch.
- ▶ Before touching, check the surface.
- ▶ If necessary, attach warning signs on the system.

4.2.6.1 Installation instructions for side-mounted braking resistors



Instructions for the installation of intrinsically safe braking resistors https://www.keb.de/fileadmin/media/Manuals/dr/ma_dr_safe-braking-resistors-20106652_en.pdf Chapter „Installation instructions“.



4.2.6.2 Terminal block X1A connection braking resistor

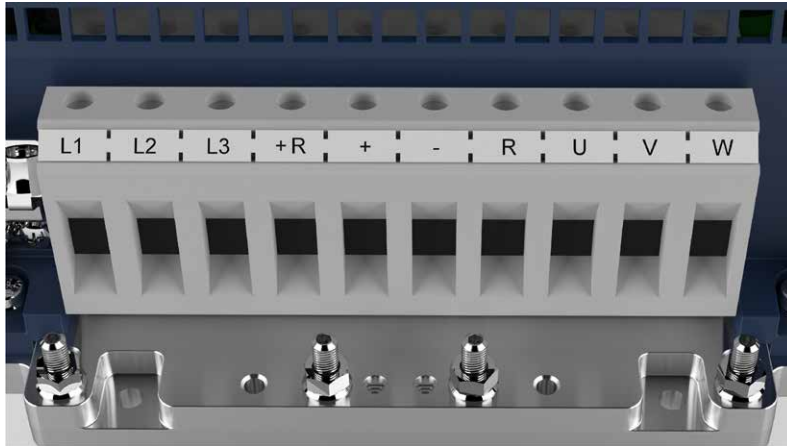

Name	Function	Cross-section for terminal connection	Tightening torque	Max. number of conductors
+R	Connection for braking resistor (between +R and R)	Flexible cable with wire-end ferrule 1.5...35 mm ² (without wire-end ferrule up to max. 50 mm ²) With 2 cables max. 16 mm ² UL: Flexible cable without wire-end ferrule AWG 16...1	3.2...3.7 Nm 28...32 lb inch	For IEC: 2 For UL: 1
R				

Figure 32: Terminal block X1A DC connection

4.2.6.3 Wiring of an intrinsically safe braking resistor

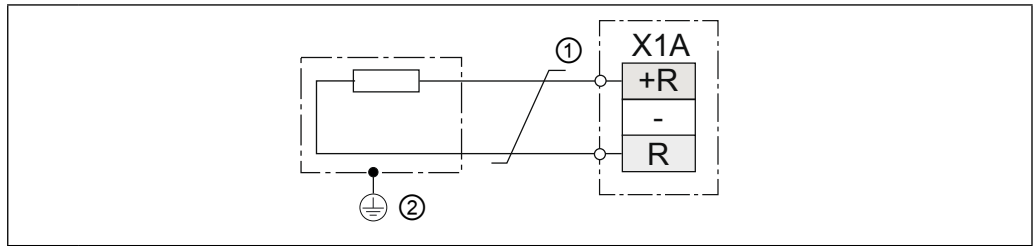

Legend

①	Twist the connection cable. When extending the connection cables, the cables must be shielded additionally and connected on both sides.
②	Protective earthing is provided via the housing.

Figure 33: Wiring of an intrinsically safe braking resistor



Intrinsically safe braking resistors behave in error case such as a safety fuse. They interrupt themselves without fire risk.

More information about intrinsically safe braking resistors

www.keb.de/fileadmin/media/Manuals/dr/ma_dr_safe-braking-resistors-20106652_de.pdf



4.2.6.4 Using a non-intrinsically safe braking resistor



Using a non-intrinsically safe braking resistor with extended temperature monitoring.

www.keb.de/fileadmin/media/Manuals/dr/ma_dr_braking-resistors-20116737_de.pdf

Chapter „Connection of a braking resistor with extended temperature monitoring“.



4.3 Accessories

4.3.1 Filters and chokes

Voltage class	Drive convertersize	HF filter	Mains choke 50 Hz / 4% U_k
230V	18	20E6T60-3000	18Z1B03-1000

Table 39: Filters and chokes for 230V devices

Voltage class	Drive convertersize	HF filter	Mains choke 50 Hz / 4% U_k
400V	19	20E6T60-3000	19Z1B04-1000
	20	20E6T60-3000	20Z1B04-1000
	21	22E6T60-3000	21Z1B04-1000
	22	22E6T60-3000	22Z1B04-1000

Table 40: Filters and chokes 400V devices



The specified filters and chokes are designed for rated operation.

4.3.2 Shield connection braket mounting kit

Name	Material number
Shield connection braket mounting kit	00F6V80-4001

Table 41: Shield connection braket mounting kit

4.3.3 Side-mounted braking resistors



Technical data and design about intrinsically safe braking resistors => https://www.keb.de/fileadmin/media/Manuals/dr/ma_dr_safe-braking-resistors-20106652_en.pdf



Technical data and design about non-intrinsically safe braking resistors => https://www.keb.de/fileadmin/media/Manuals/dr/ma_dr_braking-resistors-20116737_en.pdf



5 Installation and Operation of Liquid-Cooled Devices

5.1 Water-cooled devices

The use of water-cooled KEB COMBIVERT drive converters is offered, because there are process-caused coolants available with some applications. However, the following instructions must be observed.

5.1.1 Heat sink and operating pressure

Design system	Material	max. operating pressure	Connection
Aluminium heat sink with stainless steel tubes	Stainless steel 1.4404	10 bar	=> „ <i>Connection of the water cooling system</i> “

NOTICE

Avoid deformation of the heat sink!

- ▶ In order to avoid a deformation of the heat sink and the damages thereby, the indicated maximum operating pressure may not be exceeded briefly also by pressure peaks.
- ▶ Observe the pressure equipment directive!

5.1.2 Materials in the cooling circuit

For the screw connections and also for the metallic articles in the cooling circuit which are in contact with the coolant (electrolyte) a material is to be selected, which forms a small voltage difference to the heat sink in order to avoid contact corrosion and/or pitting corrosion (electro-chemical voltage series, see the following table). The specific case of application must be checked by the customer in tuning of the complete cooling circuit and must be classified according to the used materials. With hoses and seals take care that halogen-free materials are used.

A liability for occurring damages by wrongly used materials and from this resulting corrosion cannot be taken over!

Material	formed ion	Standard potential	Material	formed ion	Standard potential
Lithium	Li+	-3.04 V	Nickel	Ni ²⁺	-0.25 V
Potassium	K+	-2.93 V	Tin	Sn ²⁺	-0.14 V
Calcium	Ca ²⁺	-2.87 V	Lead	Pb ³⁺	-0.13 V
Sodium	Na+	-2.71 V	Iron	Fe ³⁺	-0.037 V
Magnesium	Mg ²⁺	-2.38 V	Hydrogen	2H+	0.00 V
Titan	Ti ²⁺	-1.75 V	Stainless steel	various	0.2...0.4 V
Aluminium	Al ³⁺	-1.67 V	Copper	Cu ²⁺	0.34 V
Manganese	Mn ²⁺	-1.05 V	Carbon	C ²⁺	0.74 V
Zinc	Zn ²⁺	-0.76 V	Silver	Ag+	0.80 V
Chrome	Cr ³⁺	-0.71 V	Platinum	Pt ²⁺	1.20 V

continued on the next page

Material	formed ion	Standard potential	Material	formed ion	Standard potential
Iron	Fe ²⁺	-0.44 V	Gold	Au ³⁺	1.42 V
Cadmium	Cd ²⁺	-0.40 V	Gold	Au ⁺	1.69 V
Cobald	Co ²⁺	-0.28 V			

Table 42: Electrochemical series / standard potentials against hydrogen

5.1.3 Requirements for the coolant

The requirements for the coolant depend on the ambient conditions as well as the used cooling system.

General requirements for the coolant:

Requirement	Description
Standards	Corrosion protection according to <i>EN 12502-1...5</i> , water treatment and use of materials in cooling systems according to <i>VGB R 455 P</i>
VGB Cooling water directive	The VGB cooling water directive (<i>VGB R 455 P</i>) contains instructions about common process technology of the cooling. Particularly the interactions between cooling water and components of the cooling system are described.
Abrasive substances	Abrasive substances as used in abrasive (quartz sand), clogging the cooling circuit.
Hard water	Cooling water may not cause scale deposits or loose excretions. The total hardness should be between 7...20 °dH, the carbon hardness at 3...10 °dH.
Soft water	Soft water (<7°dH) corrodes the material.
Frost protection	An appropriate antifreeze must be used for applications when the heat sink or the coolant is exposed temperatures below zero. Use only products of one manufacturer for a better compatibility with other additives. An appropriate antifreeze must be used for applications when the heat sink or the coolant is exposed temperatures below zero. For better compatibility with other additives, products from one manufacturer should preferably be used. We recommend the antifreeze Antifrogen N from Clariant with a maximum volume content of 52 %.
Corrosion protection	Additives can be used as corrosion protection. In connection with frost protection the antifreeze must have a concentration of 20...25 Vol %, in order to avoid a change of the additives.

Table 43: Requirements for the coolant

Special requirements for open and half-open cooling systems:

Impurities	Mechanical impurities in half-open cooling systems can be counteracted when appropriate water filters are used.
Salt concentration	The salt content can increase through evaporation at half-open systems. Thus the water is more corrosive. Adding of fresh water and removing of process water works against.
Algae and myxobacteria	Algae and myxobacteria can arise caused by increased water temperature and contact with atmospheric oxygen. The algae and myxobacteria clog the filters and obstruct the water-flow. Biocide containing additives can avoid this. Especially at longer OFF periods of the cooling circuit preventive maintenance is necessary.
Organic materials	The contamination with organic materials must be kept as small as possible, because separate slime can be caused by this.
<i>Table 44: Special requirements for open and half-open cooling systems</i>	



Damages at the device which are caused by clogged, corroded heat sinks or other obvious operating errors, leads to the loss of the warranty claims.

5.1.4 Connection of the water cooling system

The connection to the cooling system can occur as closed or open cooling circuit. The connection to a closed cycle cooling circuit is recommended, because the danger of contamination of coolant is very small. Preferably also a monitoring of the pH value of the coolant should be installed.

Pay attention to a corresponding conductor cross-section at required equipotential bonding in order to avoid electro-chemical procedures.

=> „5.1.2 Materials in the cooling circuit“

Other elements in the cooling circuit such as pumps, shut-off valves, ventilation etc. must be attached according to the cooling system and the local conditions.

	<table border="1"> <thead> <tr> <th data-bbox="895 696 986 741">No.</th> <th data-bbox="986 696 1428 741">Description</th> </tr> </thead> <tbody> <tr> <td data-bbox="895 741 986 896">1</td> <td data-bbox="986 741 1428 896"> Open pipe ends for the connection of the cooling system Pipe diameter outside: 10 mm Pipe diameter inside: 7...8 mm </td> </tr> </tbody> </table>	No.	Description	1	Open pipe ends for the connection of the cooling system Pipe diameter outside: 10 mm Pipe diameter inside: 7...8 mm
No.	Description				
1	Open pipe ends for the connection of the cooling system Pipe diameter outside: 10 mm Pipe diameter inside: 7...8 mm				

Figure 34: Open pipe ends for the connection of the water cooling system



Straight screw-in connections, cutting rings and union nuts (e.g. from Parker Ermeto) can be used for the connection of the cooling system.

KEB recommends the use of a volume flow switch in order to monitor the volume flow in the cooling system.

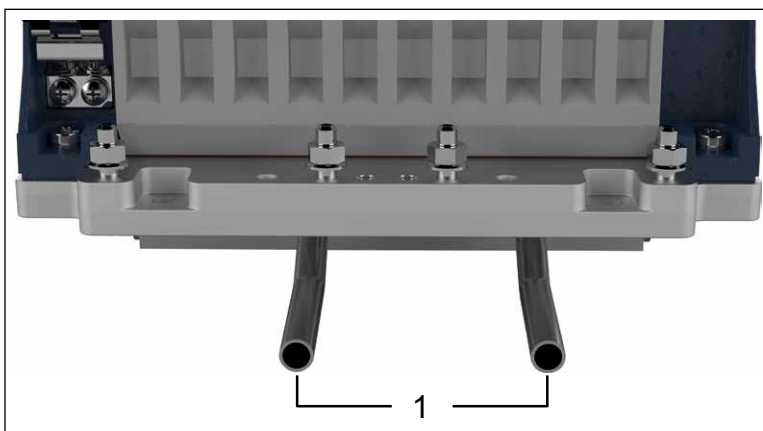
5.1.5 Coolant temperature and moisture condensation

The inlet temperature may not exceed 40°C. The maximum heat sink temperature is 90°C or 95°C depending on the power unit and overload capacity => „*Switching frequency and temperature*“. To ensure a safe operation the coolant output temperature must be 10K below this temperature.

A temperature difference between drive converter and ambient temperature can lead to condensation at high humidity.

Moisture condensation is dangerous for the drive converter . The drive converter can be destroyed through occurring short-circuits.

The inlet temperature may not exceed 40°C. The maximum heat sink temperature can be found in chapter . To ensure a safe operation the coolant output temperature should be 10K below the heat sink temperature.

A temperature difference between drive converter and ambient temperature can lead to condensation at high humidity.

Moisture condensation is dangerous for the drive converter. The drive converter can be destroyed through occurring short-circuits.

NOTICE

Destruction of the drive converter due to short circuit!

- ▶ The user must guarantee that any moisture condensation is avoided!
-

5.1.5.1 Moisture condensation

A temperature difference between drive converter and ambient temperature can lead to condensation at high humidity.

Moisture condensation is dangerous for the drive converter. The drive converter can be destroyed through occurring short-circuits.

NOTICE

Destruction of the drive converter due to short circuit!

- ▶ The user must guarantee that any moisture condensation is avoided!

5.1.5.2 Supply of temper coolant

- The supply of tempered coolant is possible by using heating units in the cooling circuit to control the coolant temperature.
- The following dew point table shows the coolant inlet temperature as a function of ambient temperature and air humidity.

Air humidity / %	10	20	30	40	50	60	70	80	90	100
Ambient temperature / °C										
-25	-45	-40	-36	-34	-32	-30	-29	-27	-26	-25
-20	-42	-36	-32	-29	-27	-25	-24	-22	-21	-20
-15	-37	-31	-27	-24	-22	-20	-18	-16	-15	-15
-10	-34	-26	-22	-19	-17	-15	-13	-11	-11	-10
-5	-29	-22	-18	-15	-13	-11	-8	-7	-6	-5
0	-26	-19	-14	-11	-8	-6	-4	-3	-2	0
5	-23	-15	-11	-7	-5	-2	0	2	3	5
10	-19	-11	-7	-3	0	1	4	6	8	9
15	-18	-7	-3	1	4	7	9	11	13	15
20	-12	-4	1	5	9	12	14	16	18	20
25	-8	0	5	10	13	16	19	21	23	25
30	-6	3	10	14	18	21	24	26	28	30
35	-2	8	14	18	22	25	28	31	33	35
40	1	11	18	22	27	31	33	36	38	40
45	4	15	22	27	32	36	38	41	43	45
50	8	19	28	32	36	40	43	45	48	50
Coolant inlet temperature / C°										

Table 45: Dew point table

NOTICE**Destruction of the heat sink at storage / transport of water-cooled devices!**

Observe the following points when storing water-cooled devices:

- ▶ Completely empty the cooling circuit
- ▶ Blow out the cooling circuit with compressed air

Destruction of the drive converter due to condensation!

- ▶ Use only NC valves!

5.1.6 Permissible flow rate with water cooling

The flow rates of the following table must be observed.

Permissible flow rate		
Min. flow rate	// min	5
Max. flow rate	// min	12,5

Table 46: Permissible flow rate with water cooling

5.1.7 Coolant heating

- Volume flow depending on the total power dissipation and temperature difference

The following graphic shows an exemplary calculation with different volume flows.

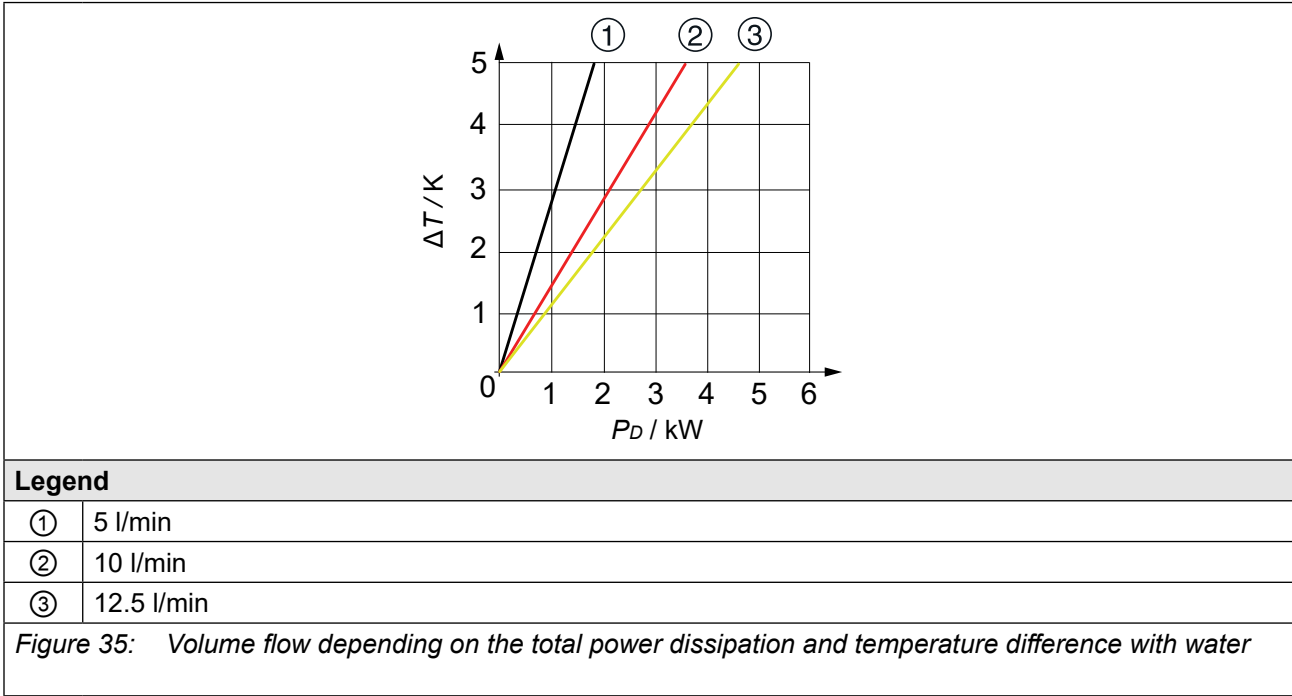

5.1.8 Typical pressure drop of the heat sink

The following graphic shows the typical pressure drop of the heat sink.

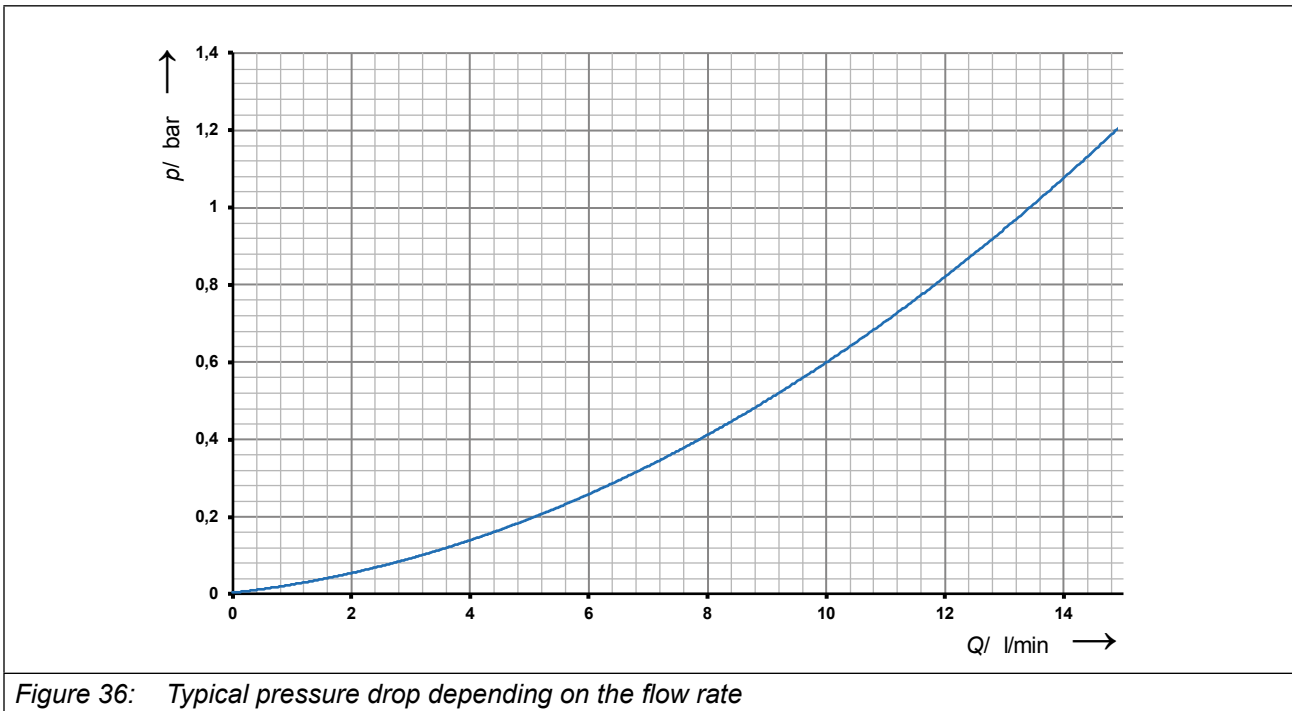

5.2 Oil-cooled devices

The following instructions must be observed when using the device.

5.2.1 Heat sink and operating pressure for oil-cooled devices

Design system	Material	max. operating pressure	Connection
Aluminium heat sink	Aluminium 3.3206	10 bar	=> „ <i>Connection of the oil cooling system</i> “

NOTICE

Deformation of the heat sink!

- ▶ In order to avoid a deformation of the heat sink and the damages thereby, the indicated maximum operating pressure may not be exceeded briefly also by pressure peaks.
- ▶ Observe the pressure equipment directive!

5.2.2 Oil requirements

General requirements for the oil:

Requirement	Description
Characteristic of the oil	Hydraulic oil HLP 46 (ISO VG 46)
Oils with appropriate properties	<ul style="list-style-type: none"> • Mobil DTE 25 • Shell Tellus Oil 46 • Castrol Hyspin ZZ 46 <p>Or similar oils</p>

Table 47: Oil requirements

Special requirements for open and half-open cooling systems:

Impurities	Mechanical impurities in half-open cooling systems can be counteracted by using appropriate filters.
Organic materials	The contamination with organic materials must be kept as small as possible, because separate slime can be caused by this.

Table 48: Special requirements for open and semi-open cooling systems for oil coolers



Damage to the device resulting from clogged heat sinks or other obvious usage failures leads to the loss of warranty claims.

5.2.3 Connection of the oil cooling system

The connection to the oil cooling system can occur as closed or open cooling circuit. Connection to a closed cooling circuit is recommended, because the risk of oil contamination is very low.

Other elements in the cooling circuit such as pumps, shut-off valves, ventilation etc. must be attached according to the cooling system and the local conditions.

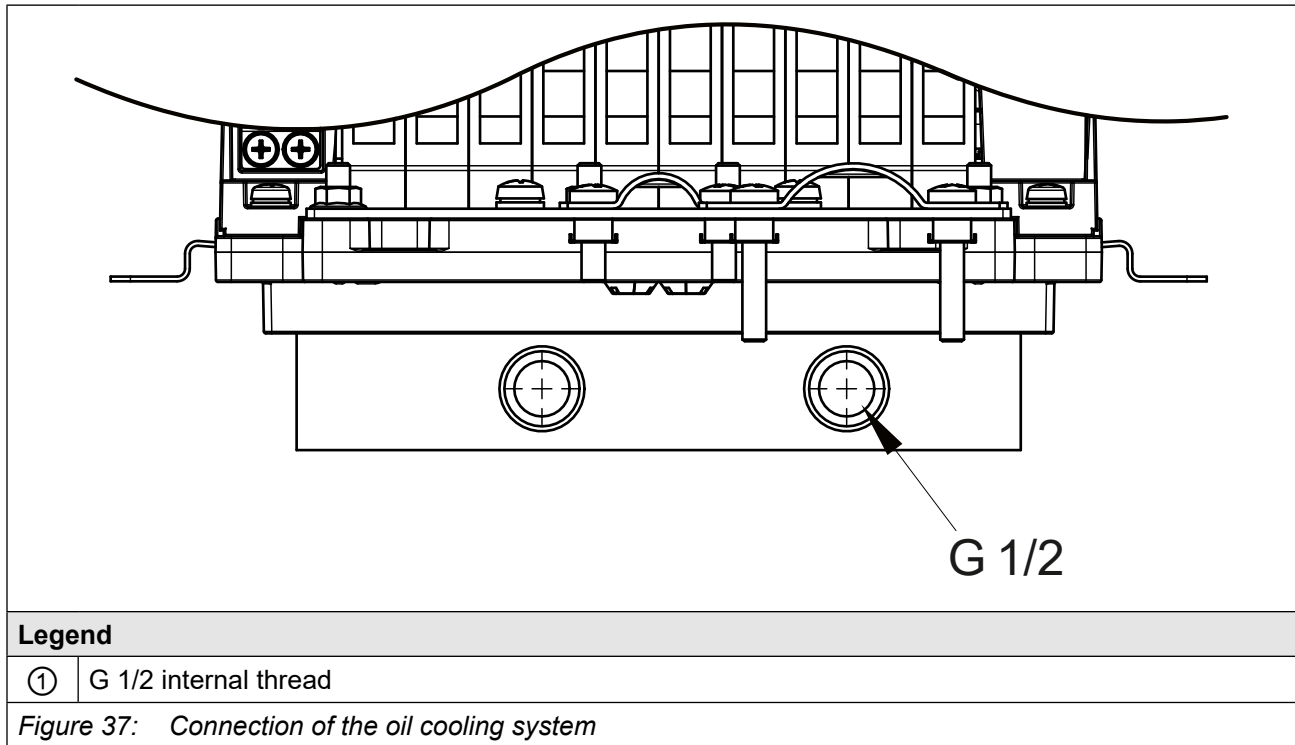

KEB recommends the use of a flow switch in order to monitor the flow in the cooling system.

5.2.4 Permissible flow rate for oil

The flow rates of the following table must be observed.

Permissible flow rate		
Min. flow rate	// min	12
Max. flow rate	// min	25

Table 49: Permissible flow rate for the oil cooler

5.2.5 Coolant temperature and moisture condensation

The inlet temperature may not exceed 55°C. The maximum heat sink temperature can be found in chapter „*Switching frequency and temperature*“. To ensure safe operation, the oil outlet temperature should be 10K below the heat sink temperature.

A temperature difference between drive converter and ambient temperature can lead to condensation at high humidity.

Moisture condensation is dangerous for the drive converter. The drive converter can be destroyed through occurring short-circuits.

NOTICE

Destruction of the drive converter due to short circuit!

- ▶ The user must guarantee that any moisture condensation is avoided!

5.2.5.1 Avoid moisture condensation

Supply of temper oil

This is possible by using heatings in the cooling circuit for the control of the coolant temperature. The following dew point table is available for this:

The following table shows the coolant inlet temperature as a function of ambient temperature and air humidity.

Air humidity / %	10	20	30	40	50	60	70	80	90	100
Ambient temperature / °C										
-25	-45	-40	-36	-34	-32	-30	-29	-27	-26	-25
-20	-42	-36	-32	-29	-27	-25	-24	-22	-21	-20
-15	-37	-31	-27	-24	-22	-20	-18	-16	-15	-15
-10	-34	-26	-22	-19	-17	-15	-13	-11	-11	-10
-5	-29	-22	-18	-15	-13	-11	-8	-7	-6	-5
0	-26	-19	-14	-11	-8	-6	-4	-3	-2	0
5	-23	-15	-11	-7	-5	-2	0	2	3	5
10	-19	-11	-7	-3	0	1	4	6	8	9
15	-18	-7	-3	1	4	7	9	11	13	15
20	-12	-4	1	5	9	12	14	16	18	20
25	-8	0	5	10	13	16	19	21	23	25
30	-6	3	10	14	18	21	24	26	28	30
35	-2	8	14	18	22	25	28	31	33	35
40	1	11	18	22	27	31	33	36	38	40
45	4	15	22	27	32	36	38	41	43	45
50	8	19	28	32	36	40	43	45	48	50
Coolant inlet temperature / C°										

Table 50: Dew point table

6 Certification

6.1 CE-Marking

CE marked drive converters were developed and manufactured to comply with the regulations of the Low-Voltage Directive and EMC directive. The harmonized standards of the series *EN 12502-1...5* and *EN 61800-3* were used.



For more information about the CE Declarations of Conformity „*Further informations and documentation*“.

6.2 UL certification



Acceptance according to UL is marked at KEB drive converters with the adjacent logo on the nameplate.

To be conform according to UL for use on the North American and Canadian Market the following additionally instructions must be observed (original text of the UL-File):

- All models: Maximum Surrounding Air Temperature: 45°C
- Use 75°C Copper Conductors Only
This marking is only applicable for all power field wiring terminals.
- Models 19F6 and 20F6: Suitable For Use On A Circuit Capable Of Delivering Not More Than 5000 rms Symmetrical Amperes, 480 Volts Maximum when protected by Class J Fuses, see instruction manual for Branch Circuit Protection details.

Models 21F6 and 22F6: Suitable For Use On A Circuit Capable Of Delivering Not More Than 10000 rms Symmetrical Amperes, 480 Volts Maximum when protected by Class J Fuses, see instruction manual for Branch Circuit Protection details.

All models: Suitable For Use On A Circuit Capable Of Delivering Not More Than 30000 rms Symmetrical Amperes, 480 Volts Maximum when protected by Semiconductor Fuses by SIBA, Type 20 189 20, or by EATON, Type 170M1368, see instruction manual for Branch Circuit Protection details.

CSA: For Canada, this marking shall be provided on the device or on a separate label shipped with the device.

Details of the prescribed Branch Circuit Protection as specified in the below section 'Branch Circuit Protection' of this Report need to be marked in the instruction manual.

- Integral solid state short circuit protection does not provide branch circuit protection. Branch circuit protection must be provided in accordance with the Manufacturer Instructions, National Electrical Code and any additional local codes.

CSA: For Canada: Integral solid state short circuit protection does not provide branch circuit protection. Branch circuit protection must be provided in accordance with the Canadian Electrical Code, Part I"

- For installations according to Canadian National Standard C22.2 No. 274-13: For use in Pollution Degree 2 and Overvoltage Category III environments only.
- Control Circuit Overcurrent Protection Required or equivalent.
- WARNING – The opening of the branch circuit protective device may be an indication that a fault current has been interrupted. To reduce the risk of fire or electrical shock, current-carrying parts and other components of the controller should be examined and replaced if damaged. If burnout of the current element of an overload relay occurs, the complete overload relay must be replaced.
- Internal Overload Protection Operates prior to reaching the 130% of the Motor Full Load Current, see manual for adjustment instructions or equivalent wording.

6.3 Further informations and documentation

You find supplementary manuals and instructions for the download under www.keb.de/de/service/downloads

General instructions

- EMC and safety instructions
- Manuals for additional control boards, safety modules, fieldbus modules, etc.

Instruction and information for construction and development

- Input fuses in accordance with UL
- Programming manual for control and power unit
- Motor configurator to select the appropriate drive converter and to create downloads for parameterizing the drive converter

Approvals and approbations

- Declaration of conformity CE
- TÜV certificate
- FS certification

Others

- COMBIVIS, the software for comfortable parameterization of drive converters via PC (available per download)
- EPLAN drawings

7 Revision History

Version	Date	Description
00	2016-04	Prototype
00	2016-09	Pre-series
01	2017-02	Pre-series, inclusion of device size 22, new CI
02	2017-07	Series, inclusion of UL certification, water cooling
03	2018-09	Corrections of technical data. Figures of the overload characteristics adapted.
04	2019-12	Editorial changes, inclusion of the 230V devices
05	2020-10	Inclusion of the oil-cooled devices

Austria | KEB Automation GmbH

Ritzstraße 8 4614 Marchtrenk Austria
 Tel: +43 7243 53586-0 Fax: +43 7243 53586-21
 E-Mail: info@keb.at Internet: www.keb.at

Benelux | KEB Automation KG

Dreef 4 - box 4 1703 Dilbeek Belgium
 Tel: +32 2 447 8580
 E-Mail: info.benelux@keb.de Internet: www.keb.de

Brazil | KEB South America - Regional Manager

Rua Dr. Omar Pacheco Souza Riberio, 70
 CEP 13569-430 Portal do Sol, São Carlos Brazil
 Tel: +55 16 31161294 E-Mail: roberto.arias@keb.de

Czech Republic | KEB Automation GmbH

Videnska 188/119d 61900 Brno Czech Republic
 Tel: +420 544 212 008
 E-Mail: info@keb.cz Internet: www.keb.cz

France | Société Française KEB SASU

Z.I. de la Croix St. Nicolas 14, rue Gustave Eiffel
 94510 La Queue en Brie France
 Tel: +33 149620101 Fax: +33 145767495
 E-Mail: info@keb.fr Internet: www.keb.fr

Germany | Geared Motors

KEB Antriebstechnik GmbH
 Wildbacher Straße 5 08289 Schneeberg Germany
 Telefon +49 3772 67-0 Telefax +49 3772 67-281
 Internet: www.keb-drive.de E-Mail: info@keb-drive.de

Italy | KEB Italia S.r.l. Unipersonale

Via Newton, 2 20019 Settimo Milanese (Milano) Italia
 Tel: +39 02 3353531 Fax: +39 02 33500790
 E-Mail: info@keb.it Internet: www.keb.it

Japan | KEB Japan Ltd.

15 - 16, 2 - Chome, Takanawa Minato-ku Tokyo 108 - 0074 Japan
 Tel: +81 33 445-8515 Fax: +81 33 445-8215
 E-Mail: info@keb.jp Internet: www.keb.jp

P. R. China | KEB Power Transmission Technology (Shanghai) Co. Ltd.

No. 435 QianPu Road Chedun Town Songjiang District
 201611 Shanghai P.R. China
 Tel: +86 21 37746688 Fax: +86 21 37746600
 E-Mail: info@keb.cn Internet: www.keb.cn

Poland | KEB Automation KG

Tel: +48 60407727
 E-Mail: roman.trinczek@keb.de Internet: www.keb.de

Republic of Korea | KEB Automation KG

Deoksan-Besttel 1132 ho Sangnam-ro 37
 Seongsan-gu Changwon-si Gyeongsangnam-do Republic of Korea
 Tel: +82 55 601 5505 Fax: +82 55 601 5506
 E-Mail: jaeok.kim@keb.de Internet: www.keb.de

Russian Federation | KEB RUS Ltd.

Lesnaya str, house 30 Dzerzhinsky MO
 140091 Moscow region Russian Federation
 Tel: +7 495 6320217 Fax: +7 495 6320217
 E-Mail: info@keb.ru Internet: www.keb.ru

Spain | KEB Automation KG

c / Mitjer, Nave 8 - Pol. Ind. LA MASIA
 08798 Sant Cugat Sesgarrigues (Barcelona) Spain
 Tel: +34 93 8970268 Fax: +34 93 8992035 E-Mail: vb.espana@keb.de

Switzerland | KEB Automation AG

Witzbergstrasse 24 8330 Pfaeffikon/ZH Switzerland
 Tel: +41 43 2886060 Fax: +41 43 2886088
 E-Mail: info@keb.ch Internet: www.keb.ch

United Kingdom | KEB (UK) Ltd.

5 Morris Close Park Farm Industrial Estate
 Wellingborough, Northants, NN8 6 XF United Kingdom
 Tel: +44 1933 402220 Fax: +44 1933 400724
 E-Mail: info@keb.co.uk Internet: www.keb.co.uk

United States | KEB America, Inc

5100 Valley Industrial Blvd. South
 Shakopee, MN 55379 United States
 Tel: +1 952 2241400 Fax: +1 952 2241499
 E-Mail: info@kebameric.com Internet: www.kebameric.com



MORE KEB PARTNERS WORLDWIDE:

... www.keb.co.uk/contact/contact-worldwide



Automation with Drive

www.keb.de

KEB Automation KG Suedstrasse 38 32683 Barntrup Tel. +49 5263 401-0 E-Mail: info@keb.de